

Artificial Intelligence

Lecture 02 - Pathfinding

Edirlei Soares de Lima

<edirlei.lima@universidadeeuropeia.pt>



Game AI – Model

- **Pathfinding**
- Steering behaviours
- Finite state machines
- Automated planning
- Behaviour trees
- Randomness
- Sensor systems
- Machine learning

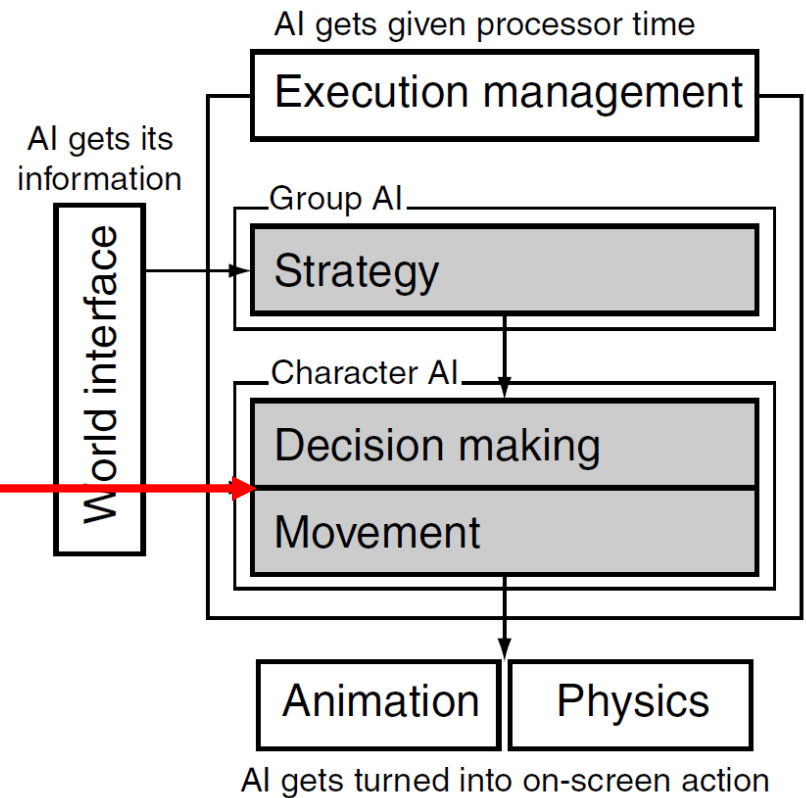

Pathfinding

- Game characters usually need to move around their level.



- While simple movements can be manually defined by game developers (patrol routes or wander regions), more complex movements must be computed during the game.

Pathfinding

- Finding a path seems obvious and natural in real life. But how a computer controlled character can do that?

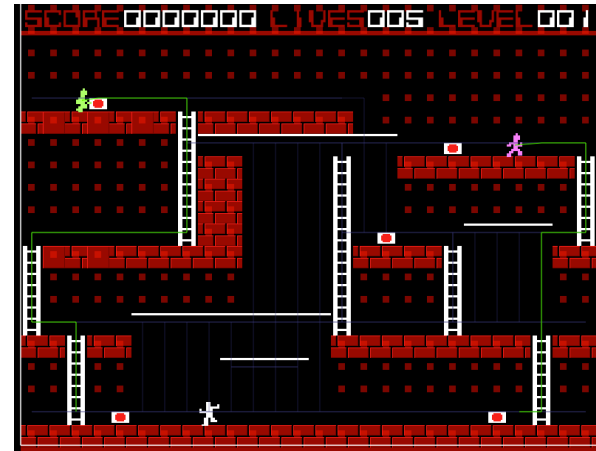

- The computer needs to find the “best” path and do it in real-time.

Search Problem

- **Pathfinding is a search problem:** find a sequence of actions from an initial state to an goal state.

- **Problem definition:**

- Initial state
- Goal state
- State space
- Set of actions
- Cost functions

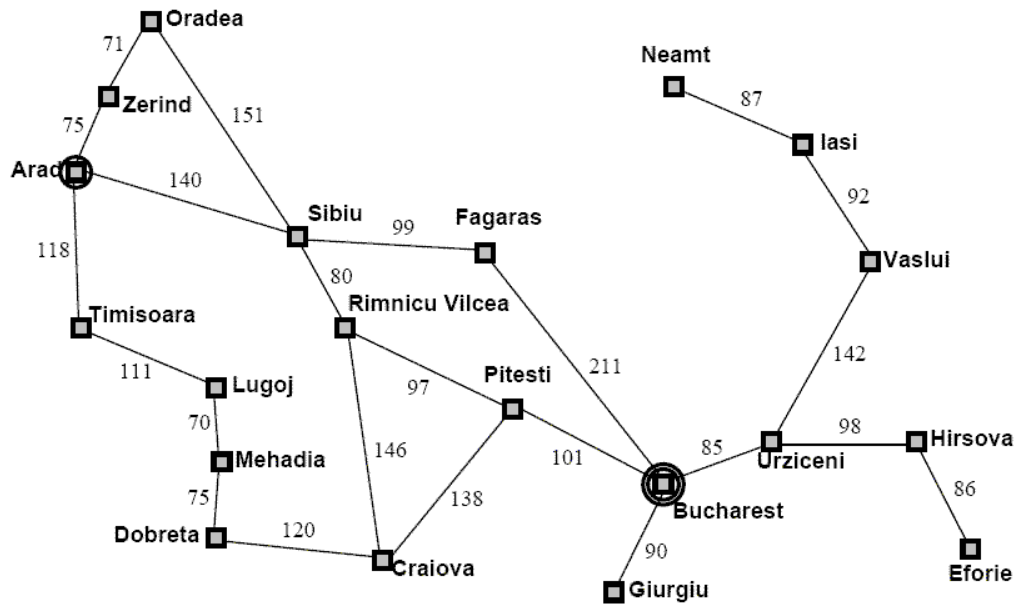

Search Problem

- The process of looking for a sequence of actions that reaches the goal is called search.
- Once a solution is found, the actions it recommends can be carried out.
- Phases:
 - Goal formulation
 - Search
 - Execution

Examples of Search Problems

- **Route-finding:**

- State space: map;
- Initial state: current city;
- Goal state: destination city;
- Set of actions: go from one city to another (only possible if there is a path between the cities);
- Action cost: distance between the cities;

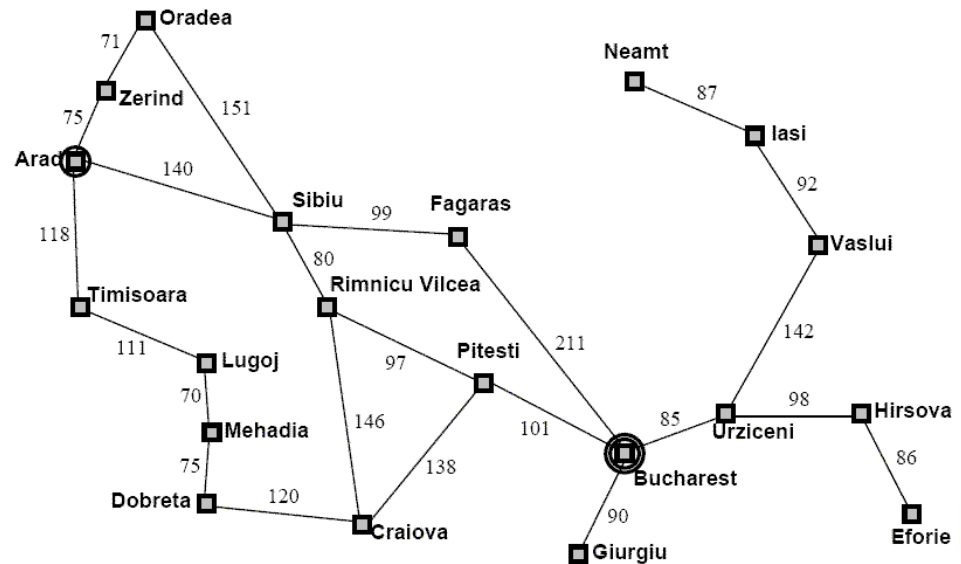

Examples of Search Problems

- **Vacuum world:**

- State space: agent location and the dirt locations (8 possible states);
- Initial state: any state;
- Goal state: all locations clean (state 7 or 8);
- Set of actions: move left, move right, and suck;
- Action cost: 1 per action;

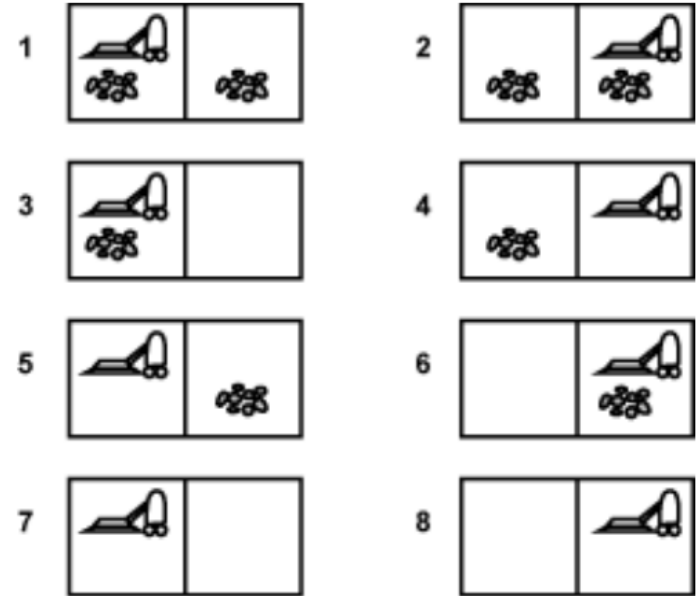

Examples of Search Problems

- **8-Puzzle Game:**

- State space: 181.440 possible states;
- Initial state: any state;
- Goal state: Goal State in the figure;
- Set of actions: move the blank space left, right, up, or down;
- Action cost: 1 per action;

15-puzzle (4x4) – 1.3 trillion possible states.

24-puzzle (5x5) – 10^{25} possible states.

7	2	4
5		6
8	3	1

Start State

	1	2
3	4	5
6	7	8

Goal State

Examples of Search Problems

- **Chess Game:**

- State space: approximately 10^{40} possible states;
- Initial state: start position of a chess game;
- Goal state: any checkmate state;
- Set of actions: pieces movement rules;
- Action cost: examined states;



General Pathfinding Problems

- State space: waypoint graphs or tiled-based maps;
- Initial state: current location (A);
- Goal state: destination location (B);
- Set of actions: movements;
- Action cost: distance or terrain difficulty;

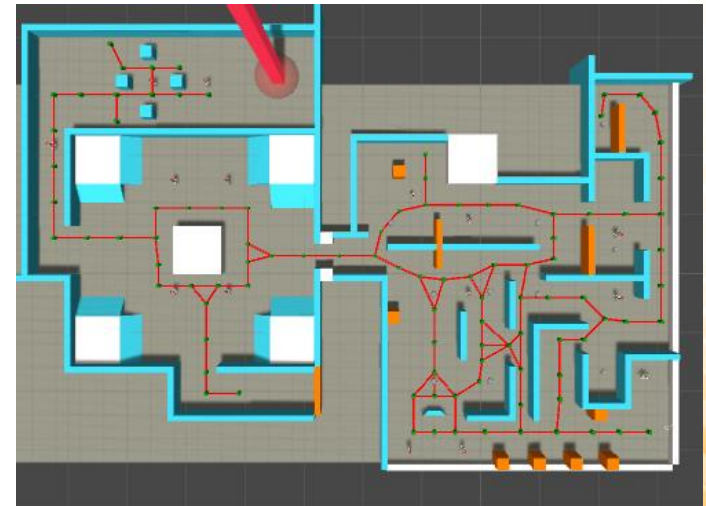
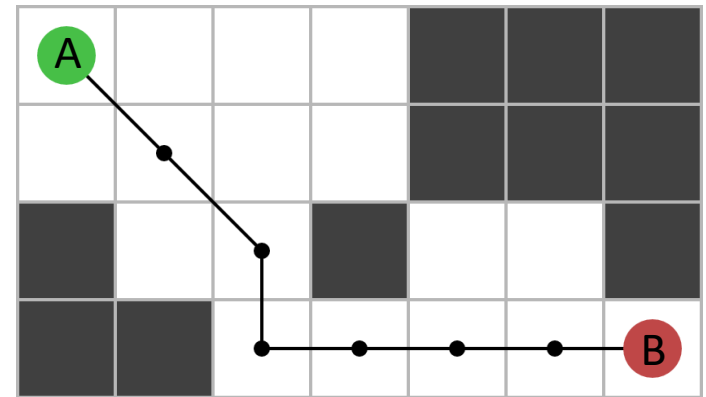

Navigation Graph

- Pathfinding algorithms can't work directly on the level geometry. They rely on a simplified version of the level, usually represented in the form of a graph.

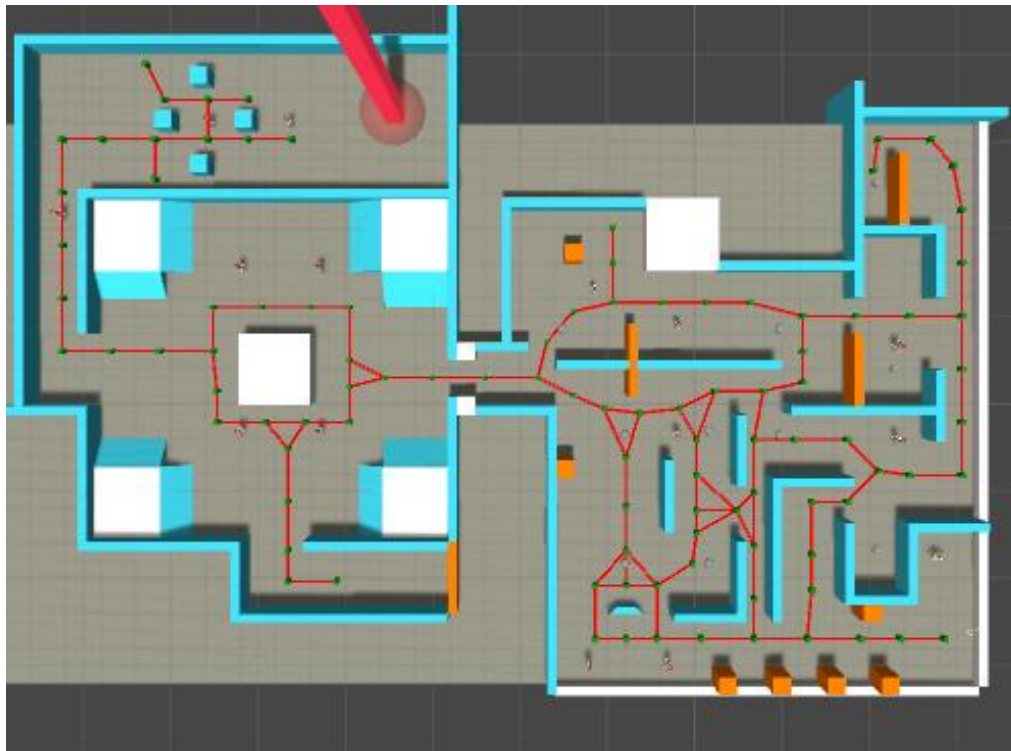

Exercise 1

- 1) Create a maze in Unity. This maze will be used to test the pathfinding algorithms. Example:

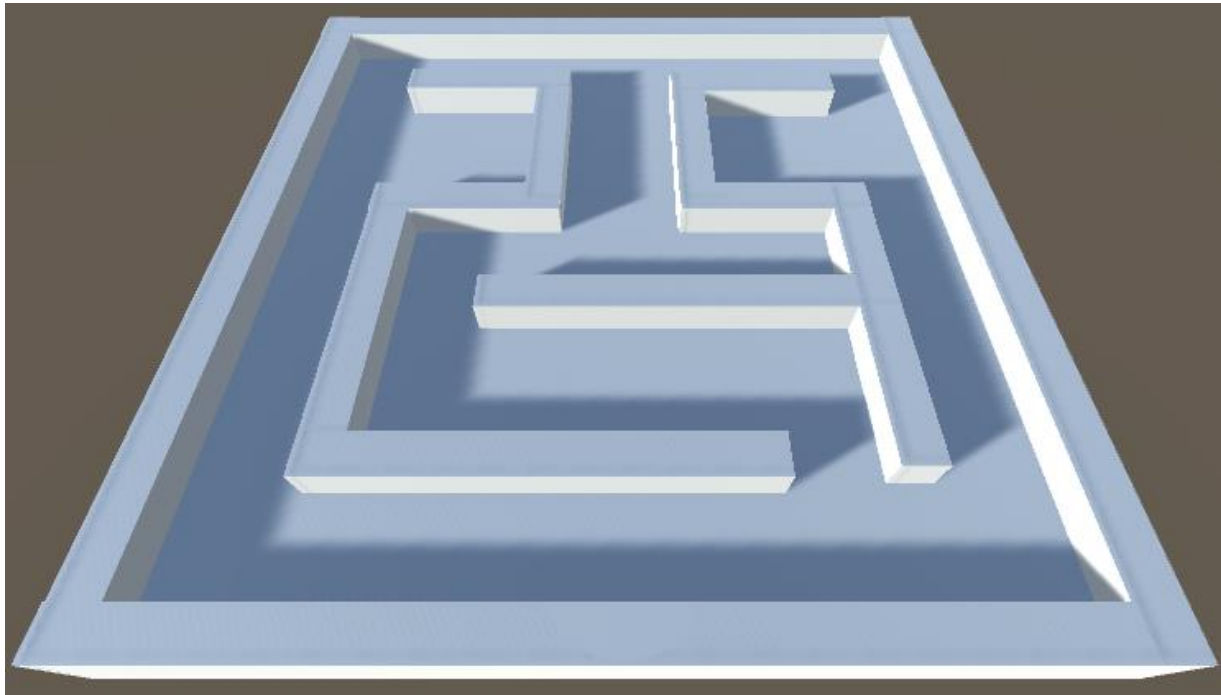

General Graph Structure

- **$G = (V, E)$**
 - G: graph;
 - V: set of vertices;
 - E: set of edges;

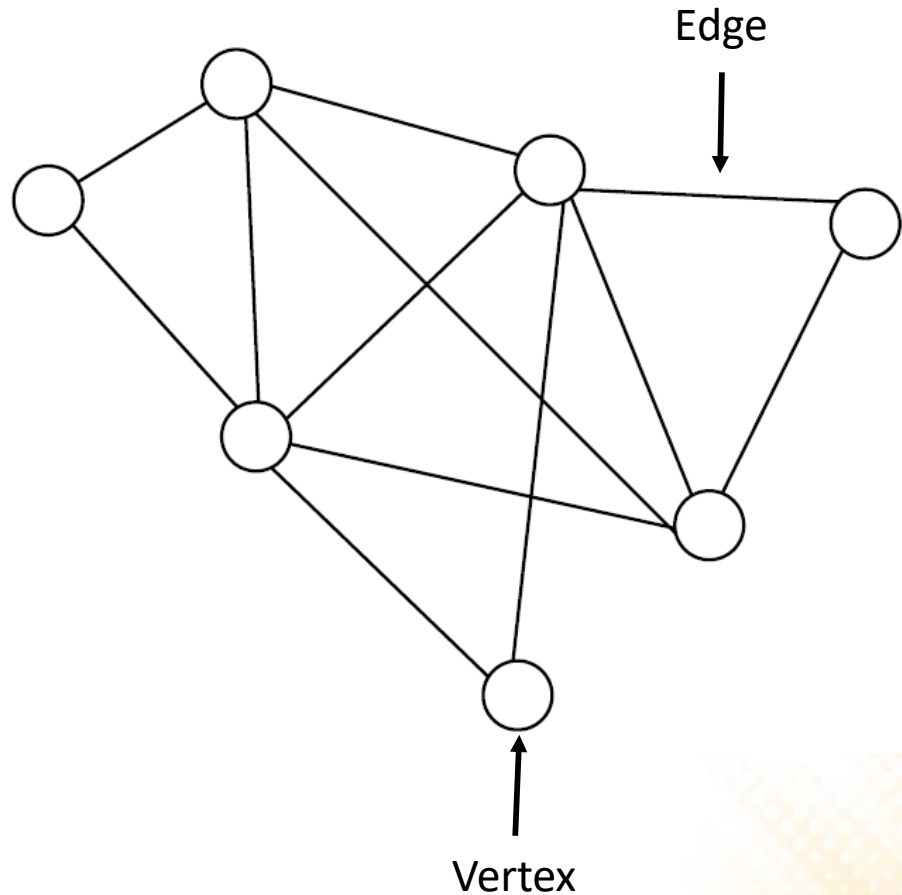

General Graph Structure

- **Directed graph:** a graph in which edges have orientations.

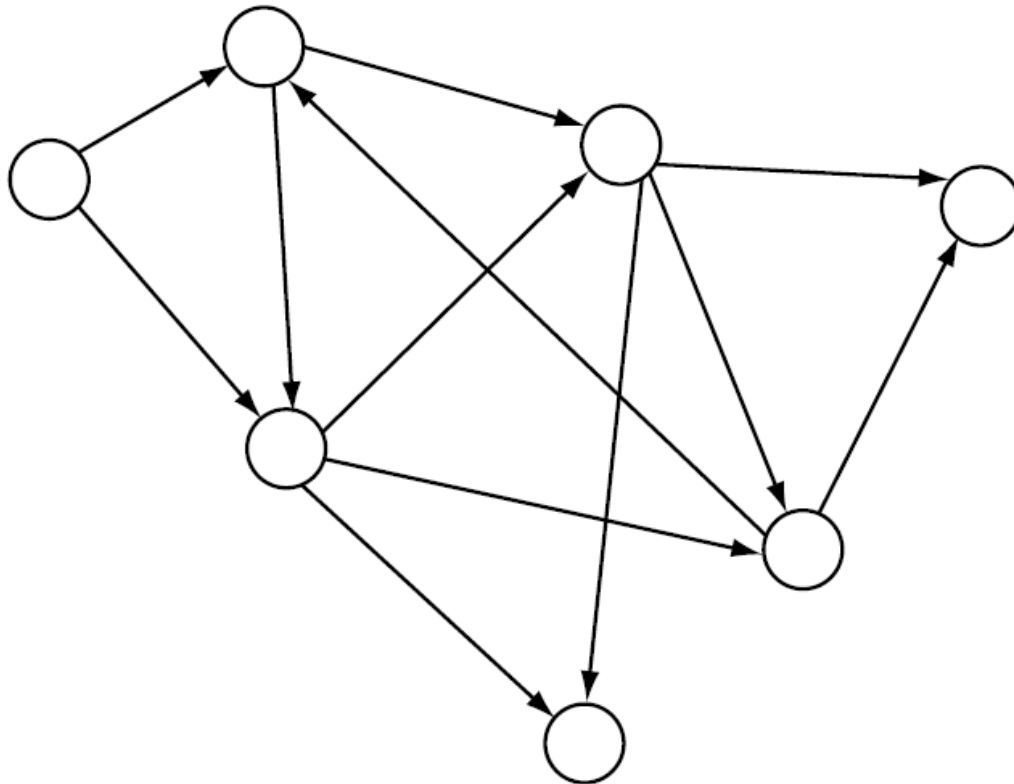

General Graph Structure

- **Weighted graph:** directed or undirected graph in which a number (the weight) is assigned to each edge.

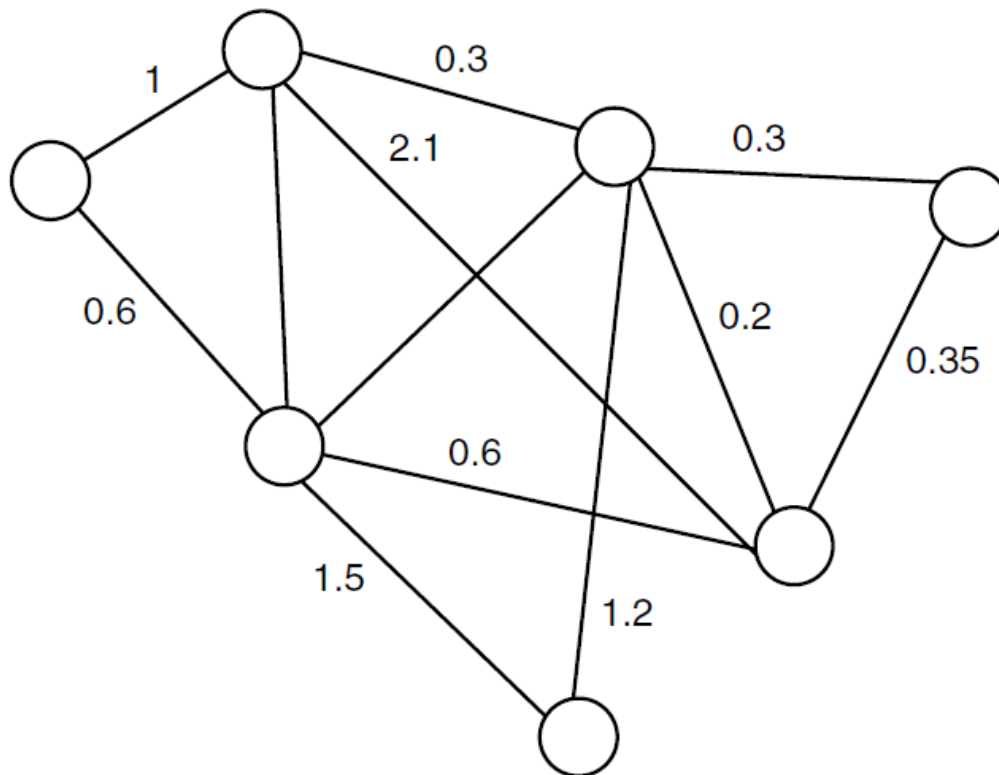

Navigation Graph

- A simplified version of the game level can be represented in the form of a graph.

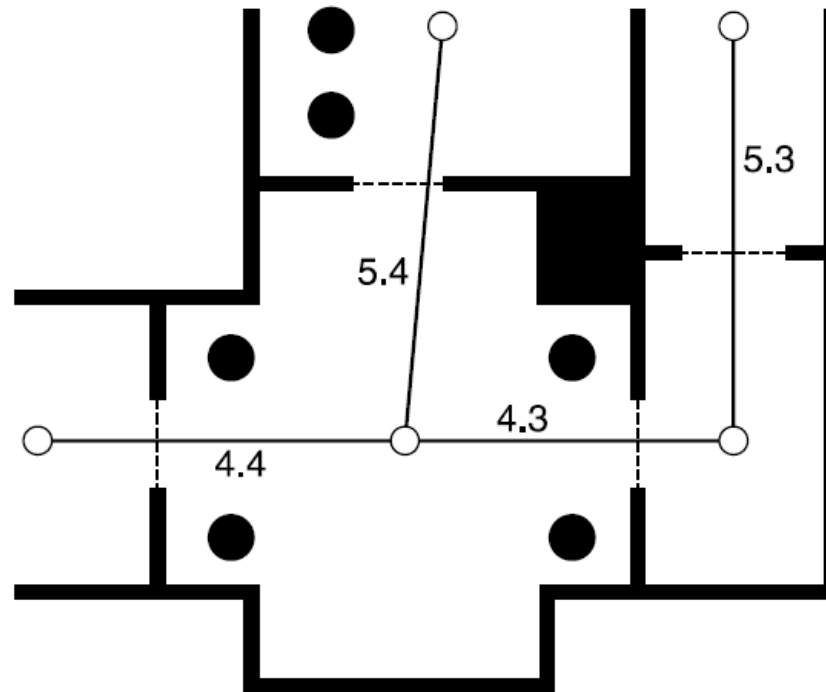

Navigation Graph

- Tiled-based maps can also be seen as graphs:

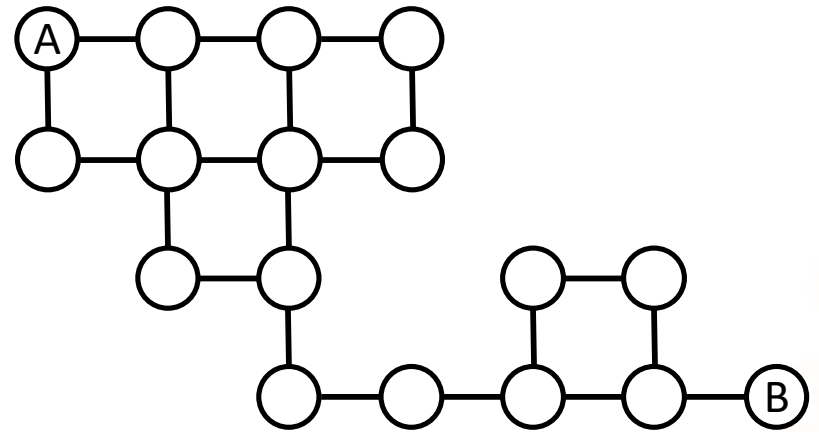
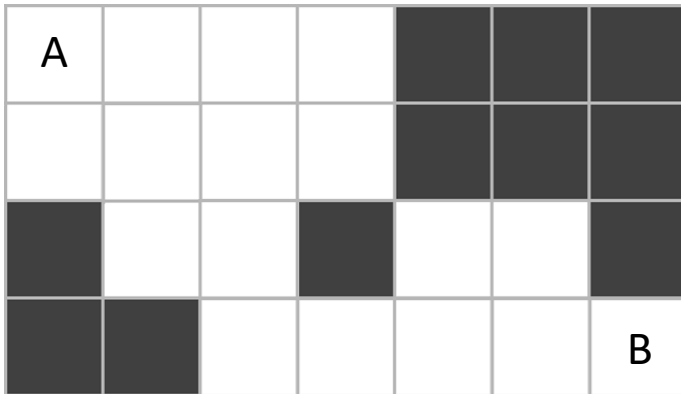

memory data:

```
0 0 0 0 1 1 1
0 0 0 0 1 1 1
1 0 0 1 0 0 1
1 1 0 0 0 0 0
```

Graph – Representation

- **Adjacency list:**
 - Uses a vector or list Adj with $|V|$ adjacency lists, one for each vertex $v \in V$.
 - For each $u \in V$, $Adj[u]$ contain references for all vertices v such that $(u, v) \in A$. That is, $Adj[u]$ contains all adjacency vertices of u .

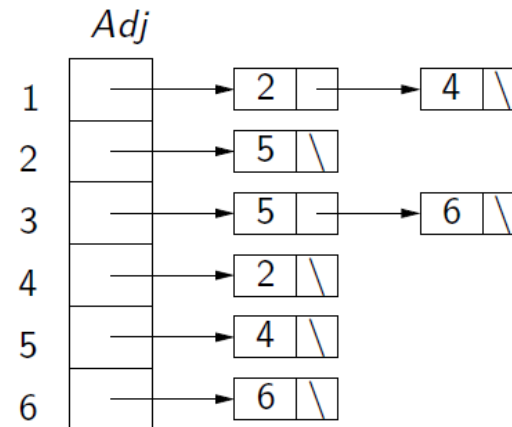
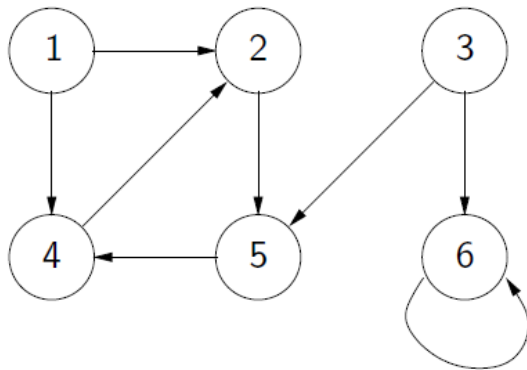

Graph – Representation

- **Adjacency matrix:**

- Given a graph $G = (V, E)$, we assume that vertices are labeled with numbers $1, 2, \dots, |V|$.
- The adjacency matrix is a matrix A_{ij} of dimensions $|V| \times |V|$, where:

$$A_{ij} = \begin{cases} 1 & \text{if } (i,j) \in A \\ 0 & \text{otherwise} \end{cases}$$

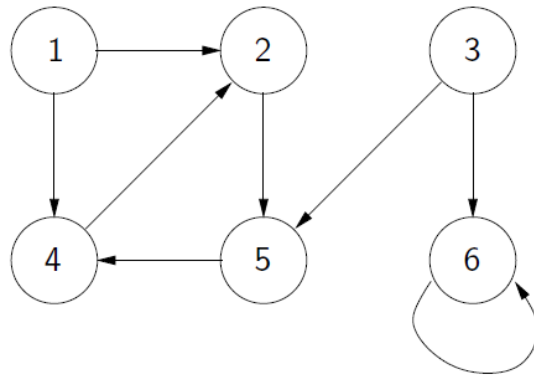

	1	2	3	4	5	6
1	0	1	0	1	0	0
2	0	0	0	0	1	0
3	0	0	0	0	1	1
4	0	1	0	0	0	0
5	0	0	0	1	0	0
6	0	0	0	0	0	1

Graph Representation in Unity

- We can easily create an adjacency list by implementing a class to represent the edges of the graph (called waypoints in the navigation graph). Each waypoint is connect with a set of other waypoints (edges):

```
public class Waypoint : MonoBehaviour {  
    public Waypoint[] edges;  
}
```

- We also need another class to store a reference to all the vertices of the graph (waypoints):

```
public class Pathfinding : MonoBehaviour {  
    public Waypoint[] waypoints;  
}
```

Graph Representation in Unity

- A waypoint also have a position in the world. But instead of adding this information to the waypoint class, a better solution is to associate the class with a game object (such a sphere) and then create a prefab.

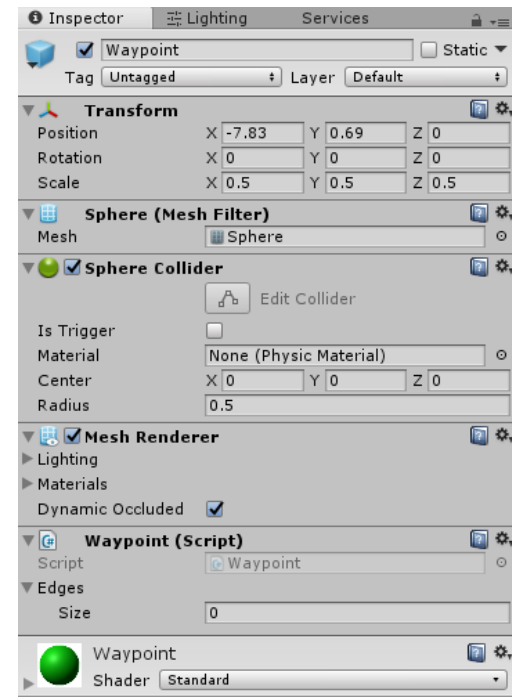
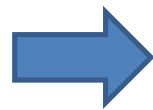
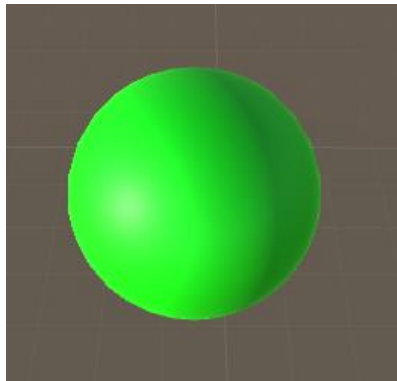

Graph Representation in Unity

- Now we can place waypoints in the game level and then connect them.

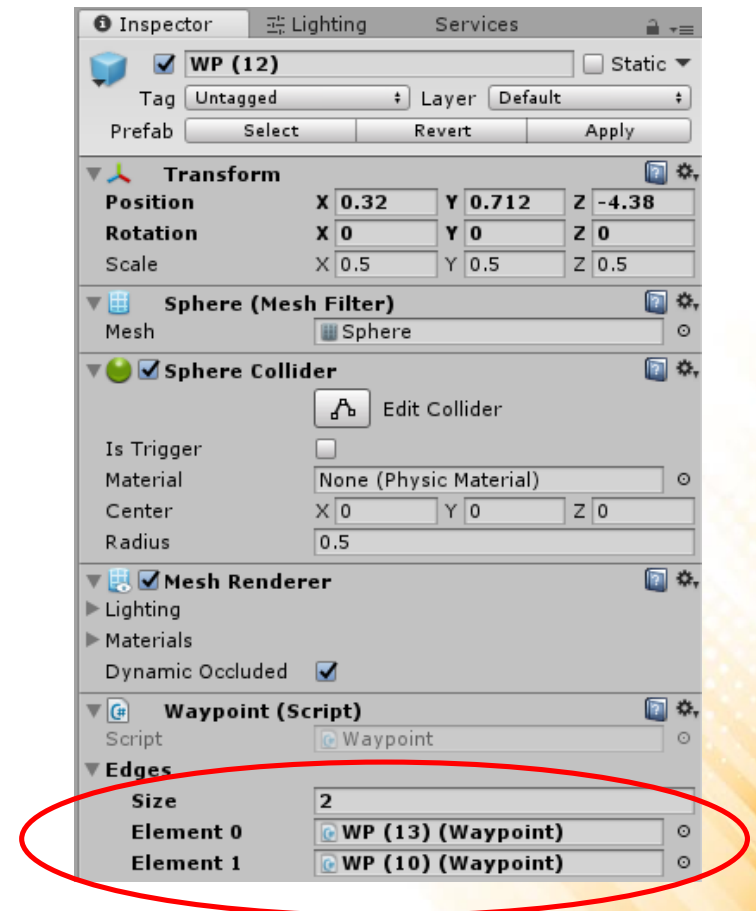
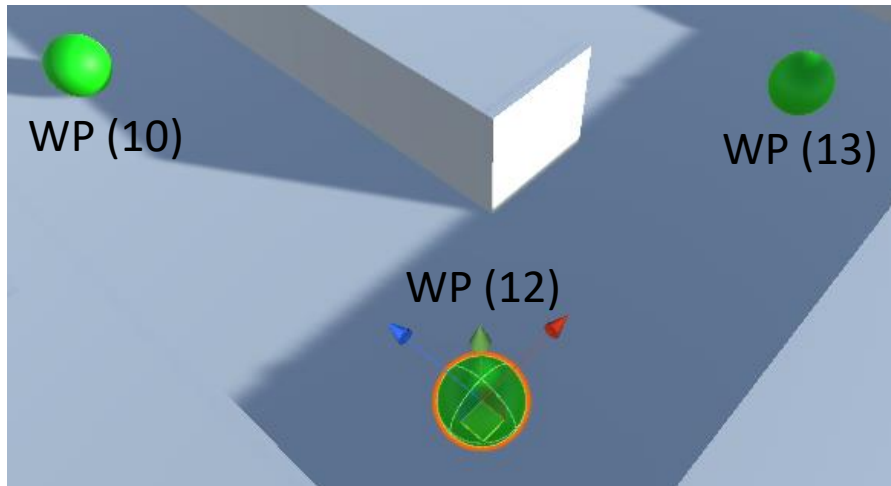

Graph Representation in Unity

- To better visualize the connections, we can use gizmos to draw lines between connected waypoints.

```
public class Waypoint : MonoBehaviour {  
    public Waypoint[] edges;  
  
    void OnDrawGizmos()  
    {  
        Gizmos.color = Color.green;  
        foreach (Waypoint e in edges)  
        {  
            Gizmos.DrawLine(transform.position,  
                             e.gameObject.transform.position);  
        }  
    }  
}
```

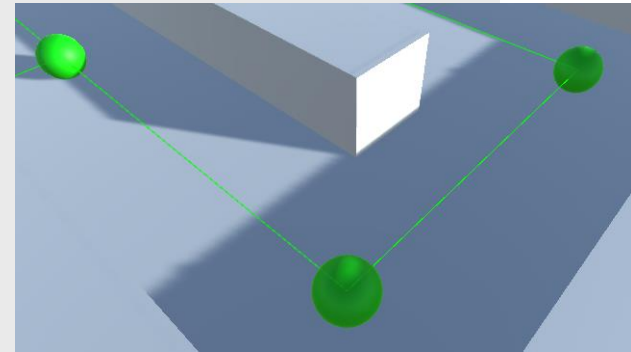

Exercise 2

- 2) Place waypoints in the visibility points of the maze created in the previous exercise. Then, connect all the waypoints to create the navigation graph.

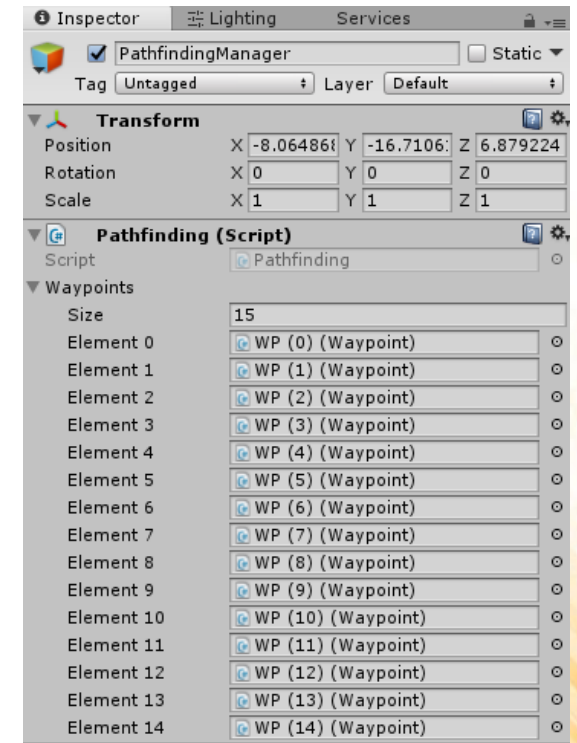
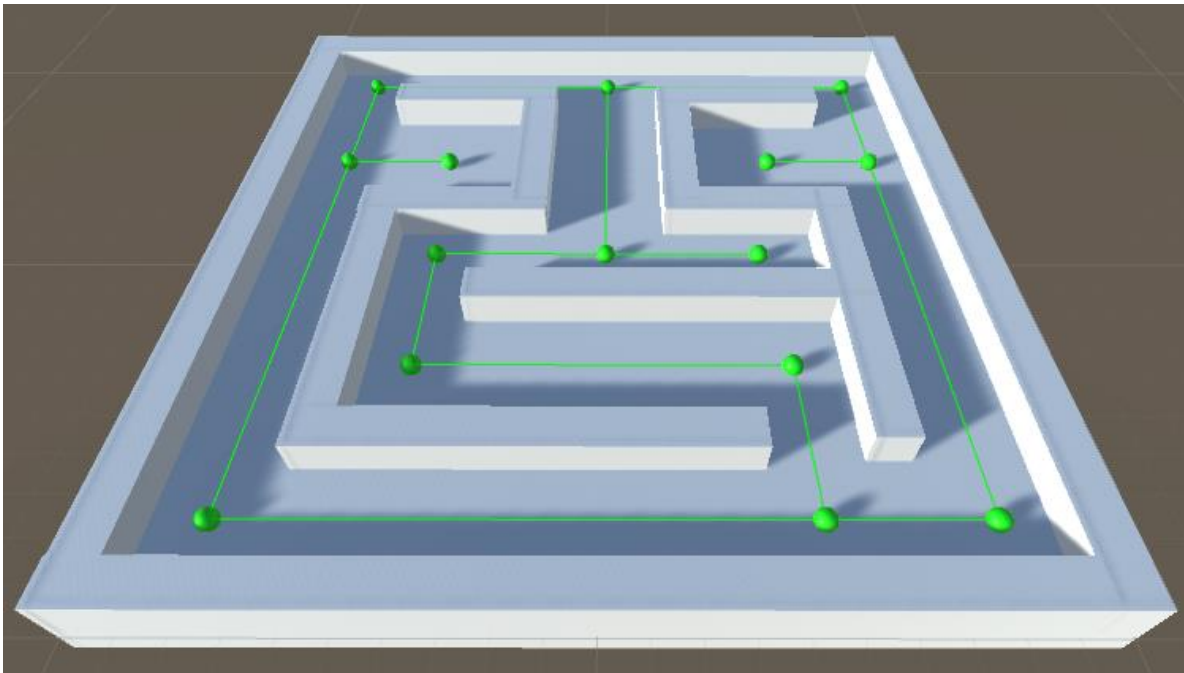

Pathfinding

- Now that we have the navigation graph, how can we find the best path to go from one waypoint to another?
 - There are many graph search algorithms:
 - Breadth-first search (BFS)
 - Depth-first search (DFS)
 - Dijkstra algorithm
 - A* algorithm
 - ...
 - Which algorithm is the best?
- 

Breadth-first Search (BFS)

- **Strategy:**

- It starts at the root vertex (any arbitrary vertex of the graph) and explores the neighbor nodes first, before moving to the next level of neighbors.

Graph:

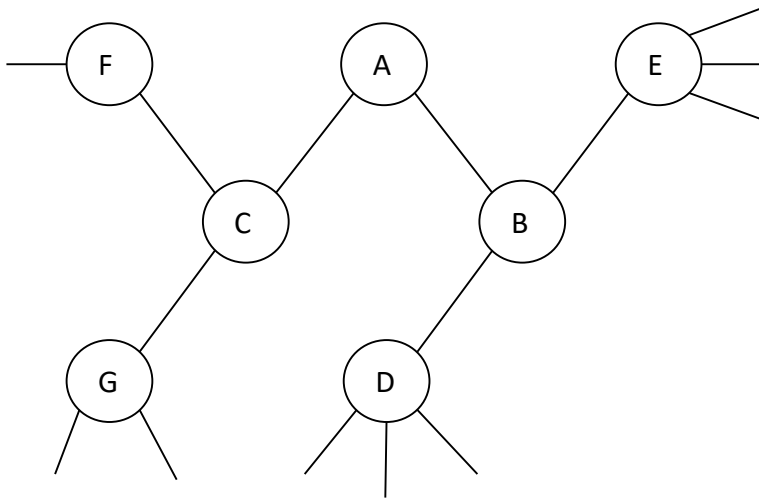

Search Tree:

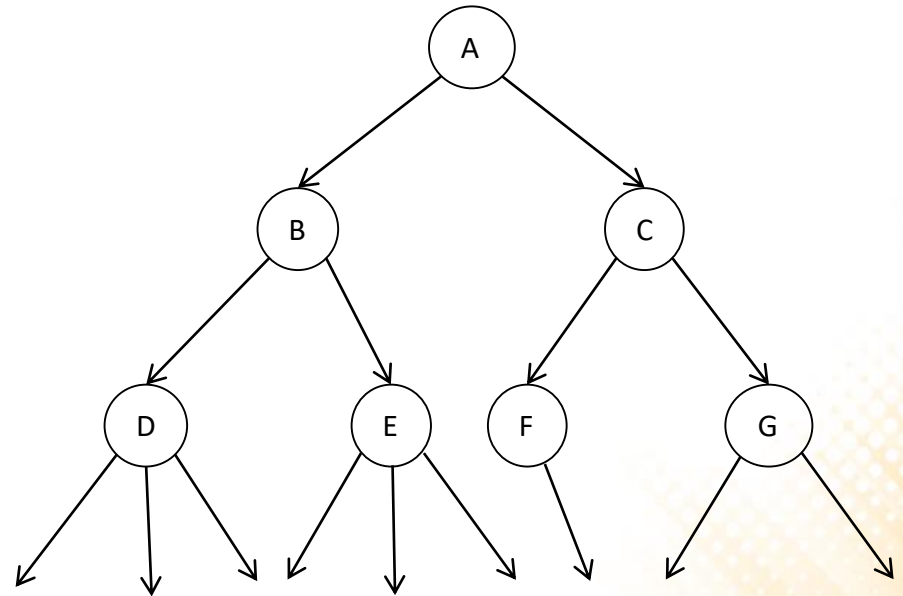

Breadth-first Search (BFS)

- Complexity: $O(b^{d+1})$

Depth	Nodes	Time	Memory
2	110	.11 milliseconds	107 kilobytes
4	11,110	11 milliseconds	10.6 megabytes
6	10^6	1.1 seconds	1 gigabyte
8	10^8	2 minutes	103 gigabytes
10	10^{10}	3 hours	10 terabytes
12	10^{12}	13 days	1 petabyte
14	10^{14}	3.5 years	99 petabytes
16	10^{16}	350 years	10 exabytes

** Considering a ramification factor $b = 10$, each node using 1KB of memory, and a processor capable of processing 1 million nodes per second.*

Depth-first Search (DFS)

- **Strategy:**

- It starts at the root vertex (any arbitrary vertex of the graph) and explores as far as possible along each branch before backtracking.

Graph:

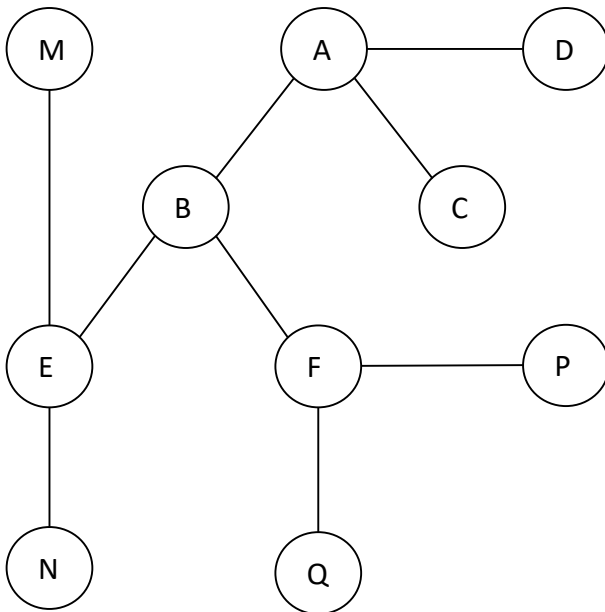

Search Tree:

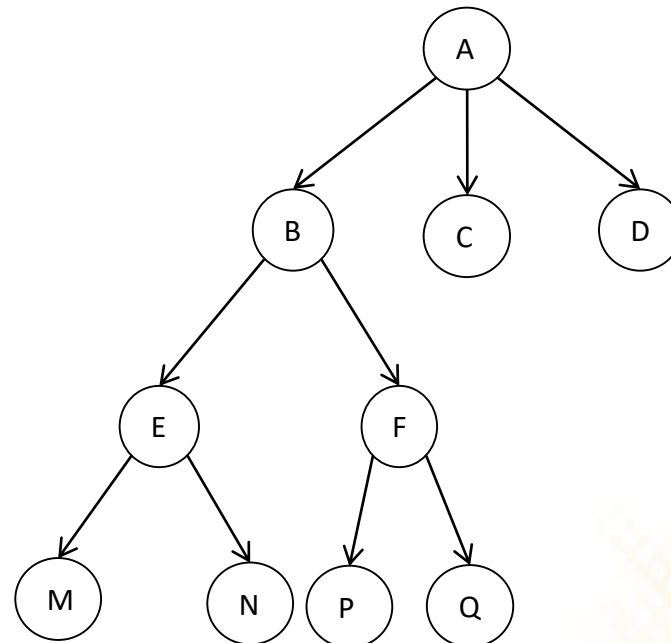

Depth-first Search (DFS)

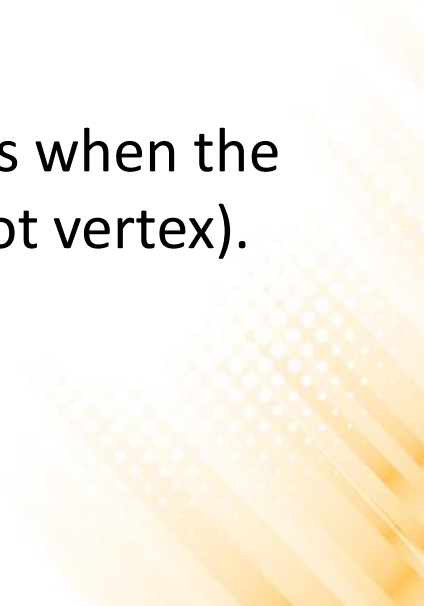
- **Consumes less memory than the BFS:** once a node has been expanded, it can be removed from memory as soon as all its descendants have been fully explored.
 - In the previous example, at depth $d = 16$, DFS would require only **156 KB of memory** (instead of 10 exabytes).
 - **Problem:** the algorithm may perform long searches when the solution is simple (when the goal is close to the root vertex).
- 

Dijkstra Algorithm

- **Strategy:**

- It starts at the root vertex (any arbitrary vertex of the graph) and explores the neighbor nodes with the lowest path cost.

Graph:

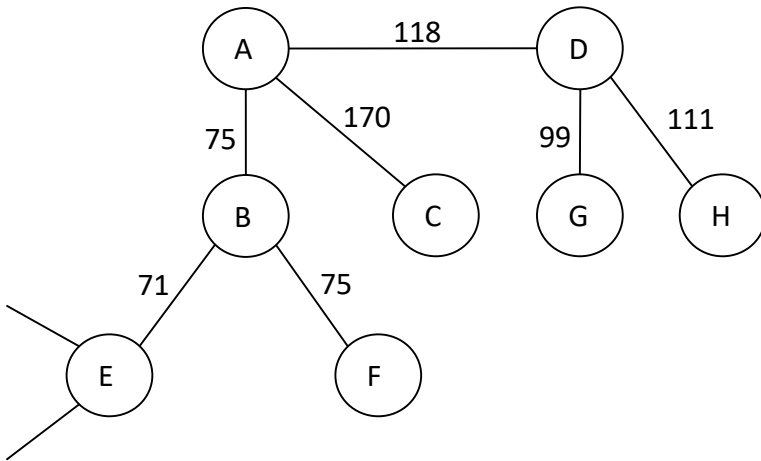

Search Tree:

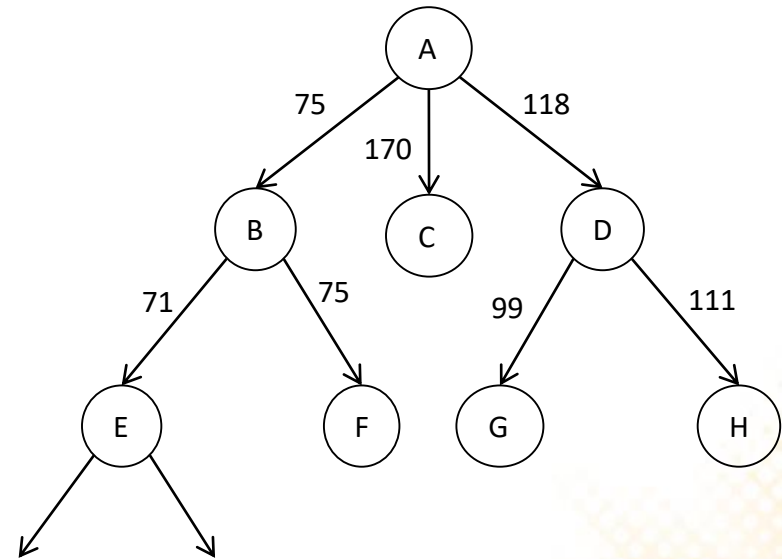

Dijkstra Algorithm

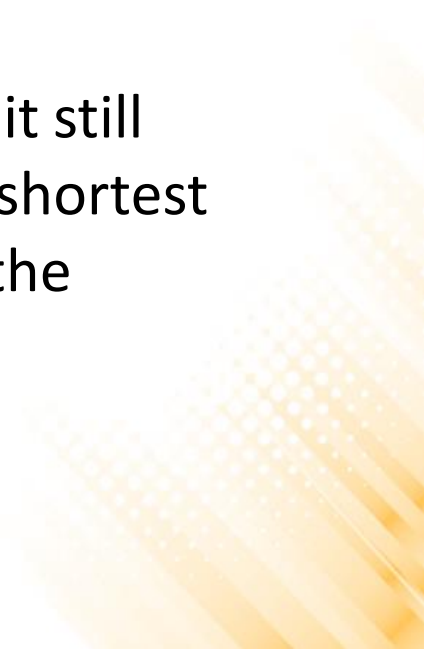
- The first solution found is always the **optimal solution** (only if there are no negative costs).
 - When all step costs are the same, Dijkstra search is similar to breadth-first search.
 - Dijkstra is better than BFS and DFS algorithms, but it still **searches the entire graph** indiscriminately for the shortest possible route (it doesn't take into consideration the objective).
- 

A* Algorithm

- **Strategy:**
 - Combines the path cost $g(n)$ with an heuristic value $h(n)$;
 - $g(n)$ = path cost from the start node to node n ;
 - $h(n)$ = estimated cost of the cheapest path from n to the goal (e.g. straight line distance);
 - The evaluation of a node is given by: $f(n) = g(n) + h(n)$;
- Pathfinding in games is synonymous with the A* algorithm. Almost every pathfinding system uses some variation of the A* algorithm.

A* Algorithm

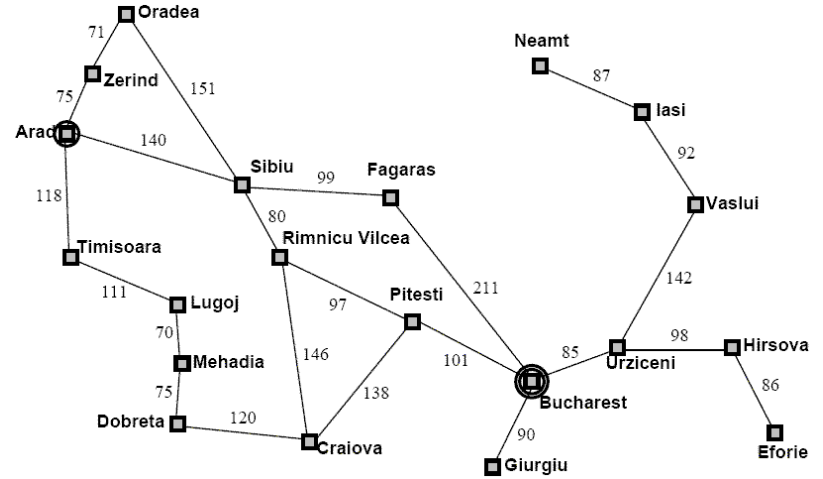
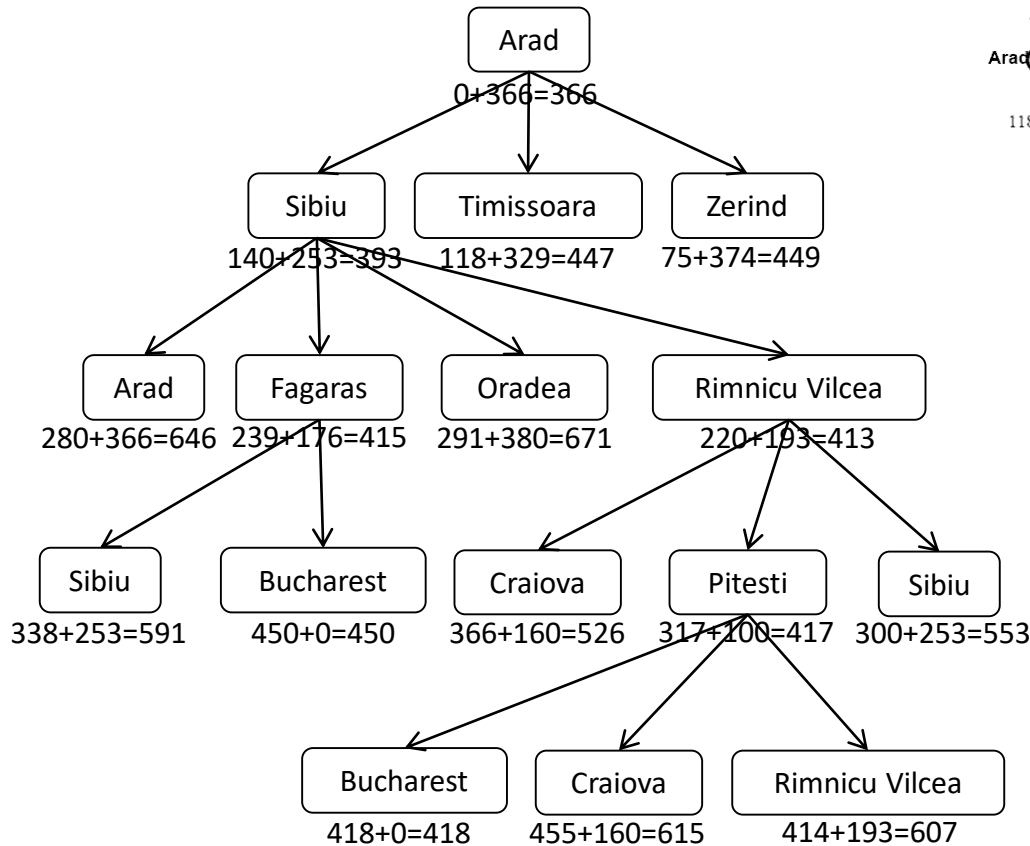

Arad	366	Mehadia	241
Bucharest	0	Neamt	234
Craiova	160	Oradea	380
Drobeta	242	Pitesti	100
Eforie	161	Rimnicu Vilcea	193
Fagaras	176	Sibiu	253
Giurgiu	77	Timisoara	329
Iasi	226	Vaslui	199
Lugoj	244	Zerind	374
Hirsova	151	Urziceni	80

A* Algorithm

- The A* algorithm is **complete** and **optimal**.
- **Complexity:** is exponential in the depth of the solution (the shortest path) – $O(b^d)$, but the heuristic function has a major effect on the practical performance of the algorithm. A good heuristic prunes away many of the b^d nodes.
- No other algorithm guarantees to expand less nodes than the A* algorithm.

A* Algorithm – Pseudocode

```
function A*(start, goal)

  closedSet := {};

  openSet := {start}; //priority queue structure

  cameFrom := an empty map;

  gScore := map with default value of Infinity;
  gScore[start] := 0;

  fScore := map with default value of Infinity;
  fScore[start] := heuristic_cost_estimate(start, goal);

  ...
```

A* Algorithm – Pseudocode

```
...
while openSet is not empty do
  current := the node in openSet having the lowest fScore[] value;
  if current = goal then
    return reconstruct_path(cameFrom, current);
  openSet.Remove(current);
  closedSet.Add(current);
  for each neighbor of current do
    if neighbor in closedSet then
      continue;
    if neighbor not in openSet then
      openSet.Add(neighbor);
    tentative_gScore := gScore[current] + dist_between(current,
                                                         neighbor);
    if tentative_gScore >= gScore[neighbor] then
      continue;
    cameFrom[neighbor] := current;
    gScore[neighbor] := tentative_gScore;
    fScore[neighbor] := gScore[neighbor] +
                       heuristic_cost_estimate(neighbor, goal);
return failure;
```

A* Algorithm – Unity

```
public List<Waypoint> FindPath(Waypoint start, Waypoint goal) {
    List<Waypoint> closedSet = new List<Waypoint>();
    SimplePriorityQueue<Waypoint> openSet = new
        SimplePriorityQueue<Waypoint>();
    openSet.Enqueue(start, Heuristic(start, goal));

    Dictionary<Waypoint, Waypoint> cameFrom = new Dictionary<Waypoint,
        Waypoint>();

    Dictionary<Waypoint, float> gScore = new Dictionary<Waypoint,
        float>();

    foreach (Waypoint wp in waypoints)
    {
        gScore.Add(wp, Mathf.Infinity);
    }
    gScore[start] = 0;

    ...
}
```

...

```
while (openSet.Count > 0){
    Waypoint current = openSet.Dequeue();
    if (current == goal)
        return ReconstructPath(cameFrom, current, start);
    closedSet.Add(current);
    foreach (Waypoint neighbor in current.edges){
        if (closedSet.Contains(neighbor))
            continue;
        if (!openSet.Contains(neighbor))
            openSet.Enqueue(neighbor, gScore[neighbor] +
                Heuristic(neighbor, goal));
        float tentative_gScore = gScore[current] + Heuristic(current,
            neighbor);
        if (tentative_gScore >= gScore[neighbor])
            continue;
        cameFrom[neighbor] = current;
        gScore[neighbor] = tentative_gScore;
        openSet.UpdatePriority(neighbor, gScore[neighbor] +
            Heuristic(neighbor, goal));
    }
}
return new List<Waypoint>();
}
```

A* Algorithm – Unity

```
float Heuristic(Waypoint p1, Waypoint p2){
    return Vector3.Distance(p1.gameObject.transform.position,
                           p2.gameObject.transform.position);
}

List<Waypoint> ReconstructPath(Dictionary<Waypoint,Waypoint> cameFrom,
                               Waypoint current, Waypoint start){
    List<Waypoint> total_path = new List<Waypoint>();
    total_path.Add(current);
    while (current != start){
        foreach (Waypoint wp in cameFrom.Keys){
            if (wp == current){
                current = cameFrom[wp];
                total_path.Add(current);
            }
        }
    }
    total_path.Reverse();
    return total_path;
}
```



Exercise 3

3) Implement the A* algorithm in the Pathfinding class created in the previous exercises.

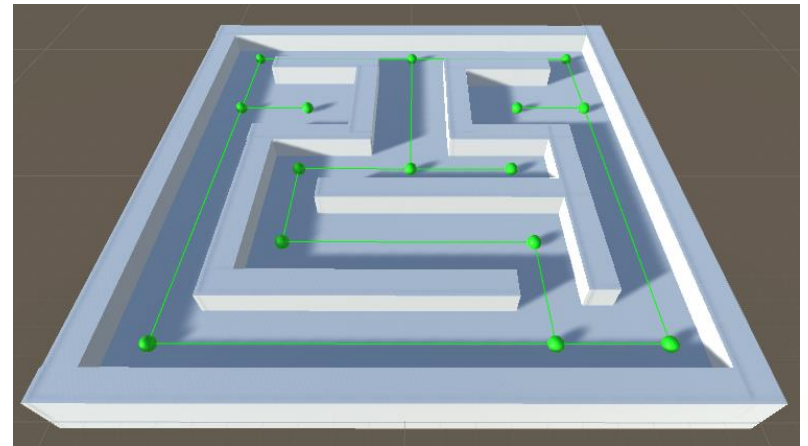
- a) Execute the FindPath function and show the resulting path in the console;
- b) Add parameters to define the start and goal waypoints;
- c) Test the algorithm with different start and goal waypoints;

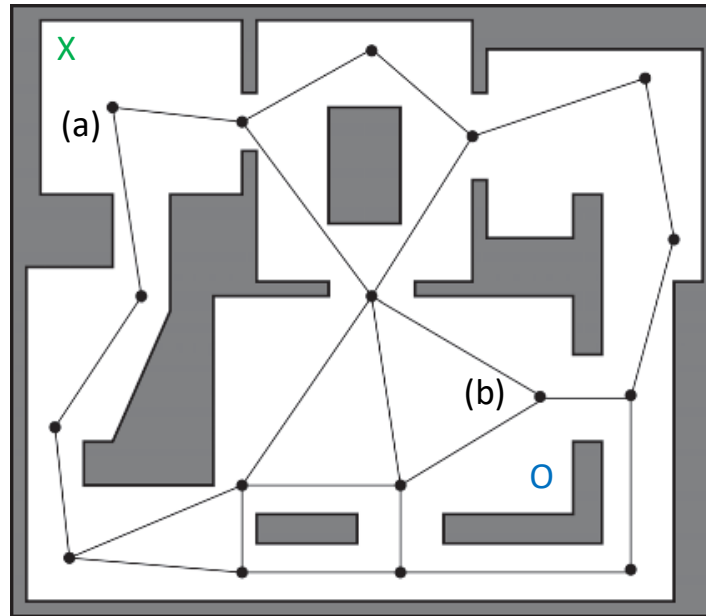

Navigation



1. Find closest visible node (a) to current location (X);
2. Find closest visible node (b) to target location (O);
3. Search for the best path from (a) to (b);
4. Move to (a);
5. Follow path to (b);
6. Move to target location (O);

Exercise 4

- 4) Add an object (e.g. a capsule) to represent an NPC and then use the pathfinding algorithm to move the NPC from any place to any goal destination.
 - a) Create a function to find the closest waypoint to use as start and goal waypoints;
 - b) Move the NPC slowly through the computed path;

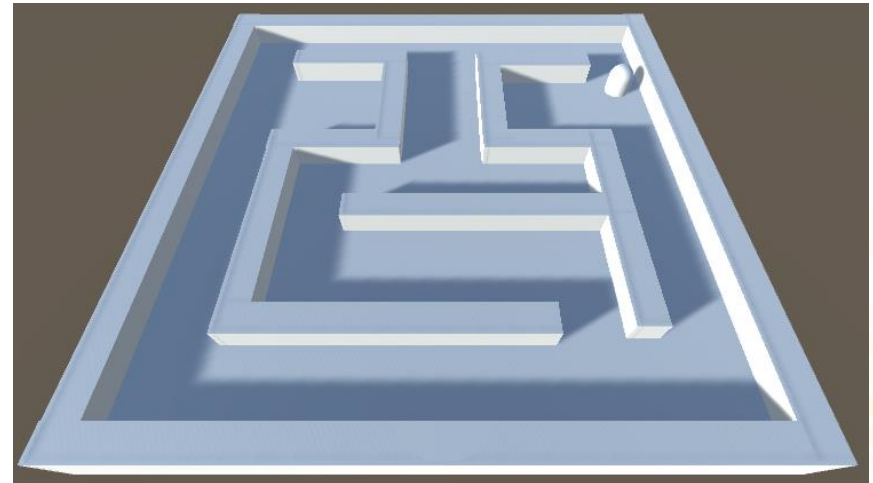

World Representations

- Pathfinding algorithms don't work directly on the level geometry. They rely on a simplified world representation.
- Most common techniques for world representation:
 - Tile Graphs;
 - Points of Visibility;
 - Finely Grained Graphs;
 - Expanded Geometry;
 - Navigation Meshes;

Tiled-Based Graphs

- Tile-based levels split the whole world into regular, usually square, regions (although hexagonal regions are occasionally seen in some games).
 - The whole level can be tiled-based or the tile grid overlays the 3D level;

- **Advantages:** tile-based graphs are generated automatically. Easy to estimate edge's weights.
- **Problems:** the search spaces can quickly become extremely large (a 100x100 map has 10,000 nodes and 78,000 edges!). If no path smoothing techniques are applied, character's movements will be unnatural.

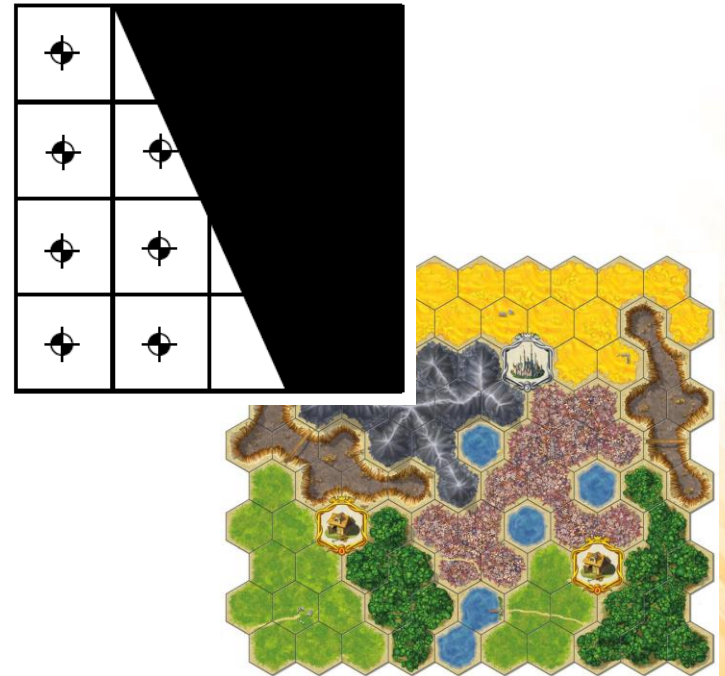

Points of Visibility (POV)

- A points of visibility navigation graph is created by placing waypoints at important points in the environment such that each waypoint has line of sight to at least one other.
 - Usually the waypoints are placed by hand (level designer task);
- **Advantages:** easy to implement. Easy to include extra information about waypoints (e.g. good sniping, cover, or ambush positions).
- **Problems:** large maps require a lot of work to place all waypoints manually. Problematic if the game includes map generation features. Blind spots problem.

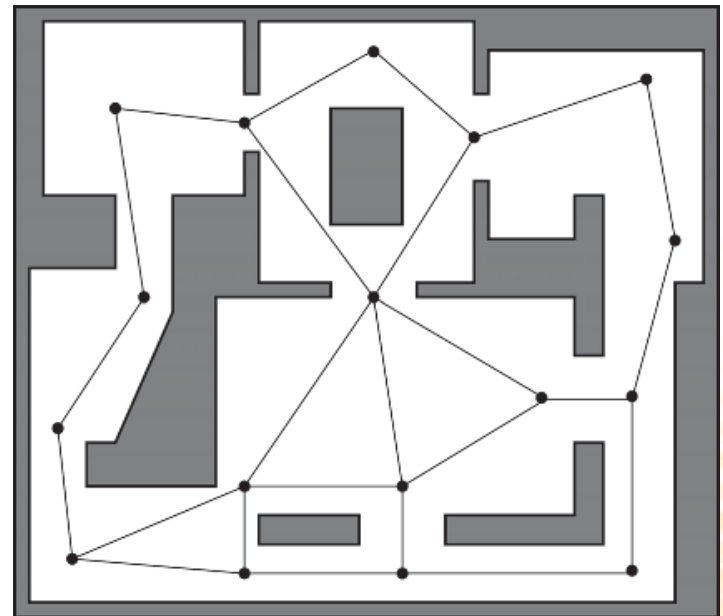

Expanded Geometry

- A POV graph can be automatically generated using the expanded geometry technique.
 - a) Expand geometry (by a amount proportional to the bounding radius of moving agents);
 - b) Connect all vertices;
 - c) Remove non-line of sight edges;

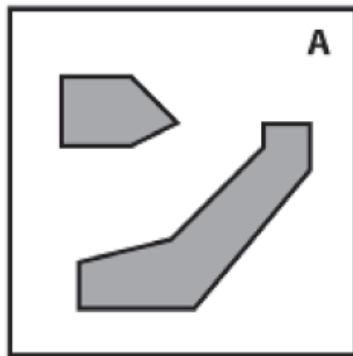

Simple Geometry

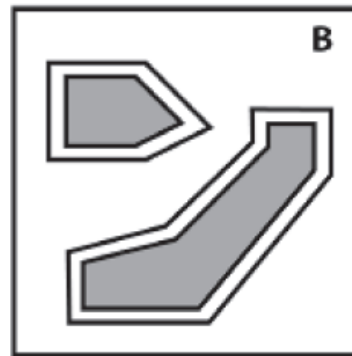

Expanded Geometry

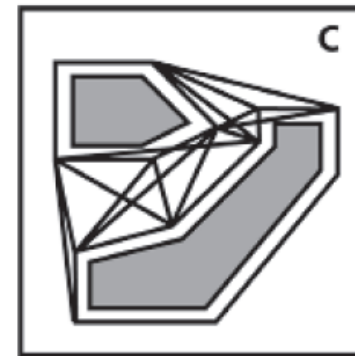

The finished POV graph

Finely Grained Graphs

- Poor paths and inaccessible positions can be improved by increasing the granularity of the navigation graph.
- **Advantages:** Removes blind spots and improves path smoothness. Can be generated automatically using “flood fill” algorithm.
- **Problems:** can have similar performance issues as tiled graphs.

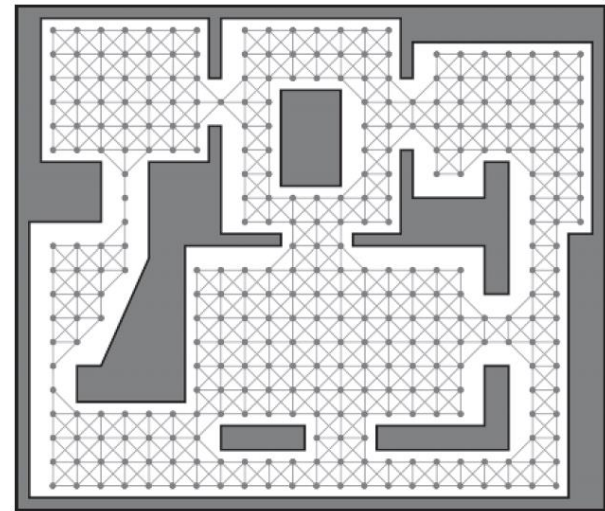

Finely Grained Graphs – Flood Fill

1. Place a seed node somewhere in the map;
2. Expand the nodes and edges outward from the seed in each available direction (e.g. 8 directions), and then the nodes on the fringe of the graph;
 - Check for collisions with the level geometry;
3. Continue until all the navigable area is filled.

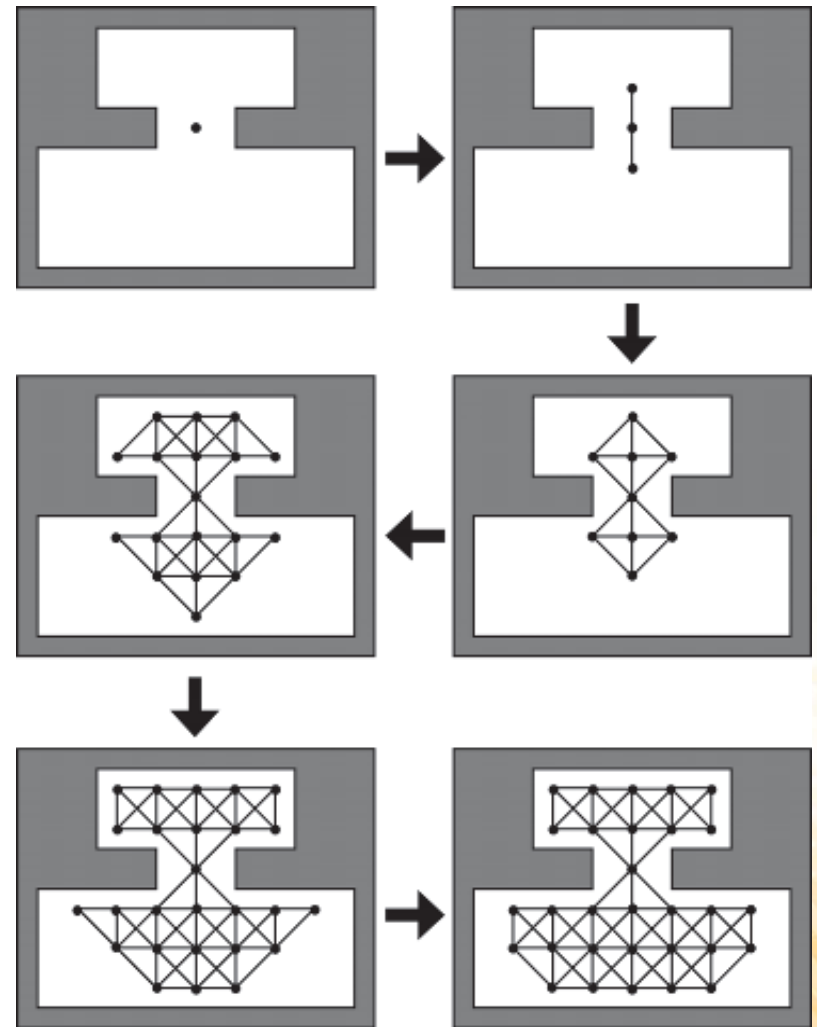

Path to an Item Type

- What to do when we need a path to an item type (such as a rocket launcher) that can be found in several locations?
 - In this situation, Dijkstra's algorithm is a better choice.

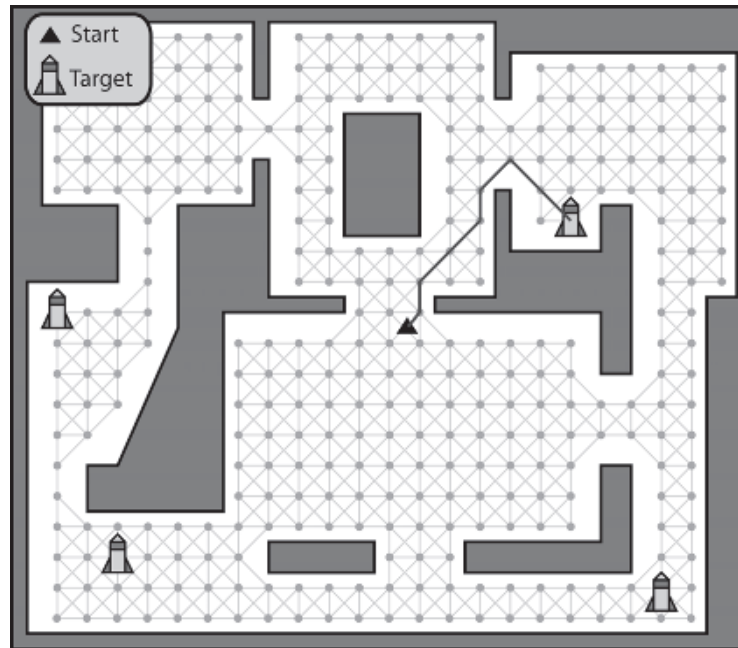

Path Smoothing

- When the navigation graph is in the shape of a grid or when the path have unnecessary edges, the movements of the agent may look unnatural.
- **Solution:** Path Smoothing

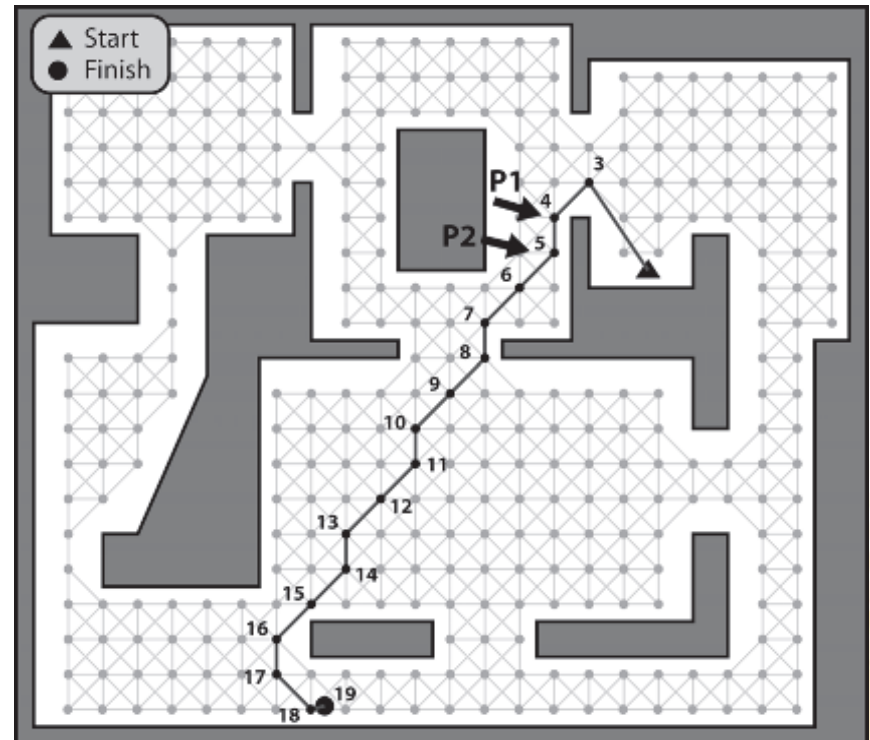

Simple Path Smoothing Algorithm

- Check for the “passability” between adjacent edges. If one of the edges is superfluous, the two edges are replaced with one.
 - “passability” can be checked through a ray-cast. If we can cast a ray between A and C then waypoint B is not needed.

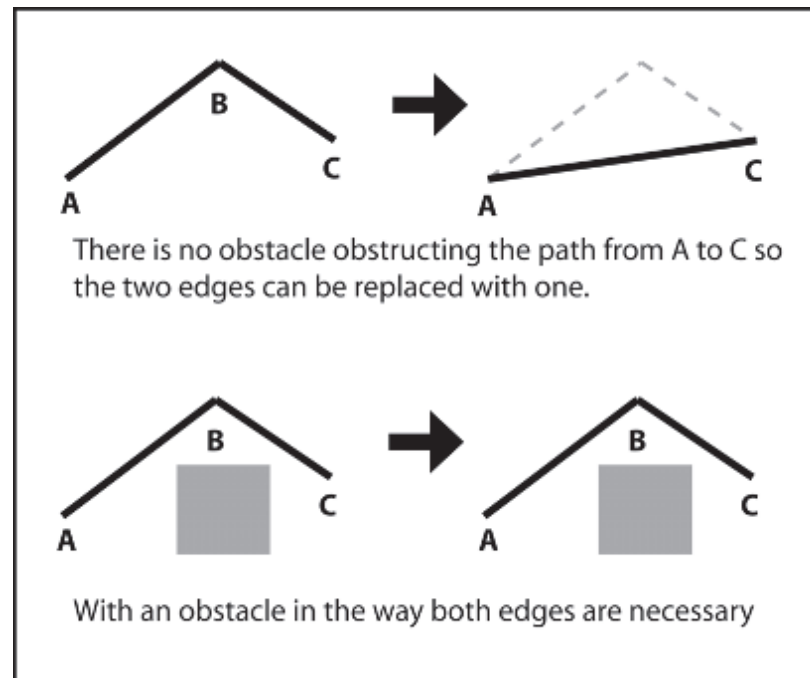

Simple Path Smoothing Algorithm

1. Grab source E1 (edge);
2. Grab destination E2 (edge);
3. If the agent can move between the source of E1 and destination of E2:
 - a) Assign the destination of E1 to the destination of E2;
 - b) Remove E2;
 - c) Advance E2;
4. If the agent cannot move between the source of E1 and destination of E2:
 - a) Assign E2 to E1;
 - b) Advance E2;
5. Repeat until the destination of E1 or destination of E2 is the endpoint of the path;

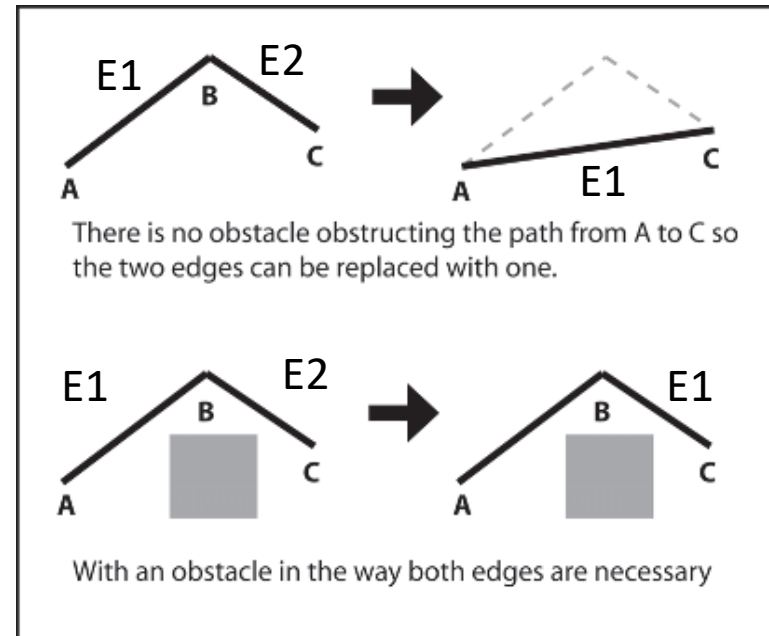

Simple Path Smoothing Algorithm

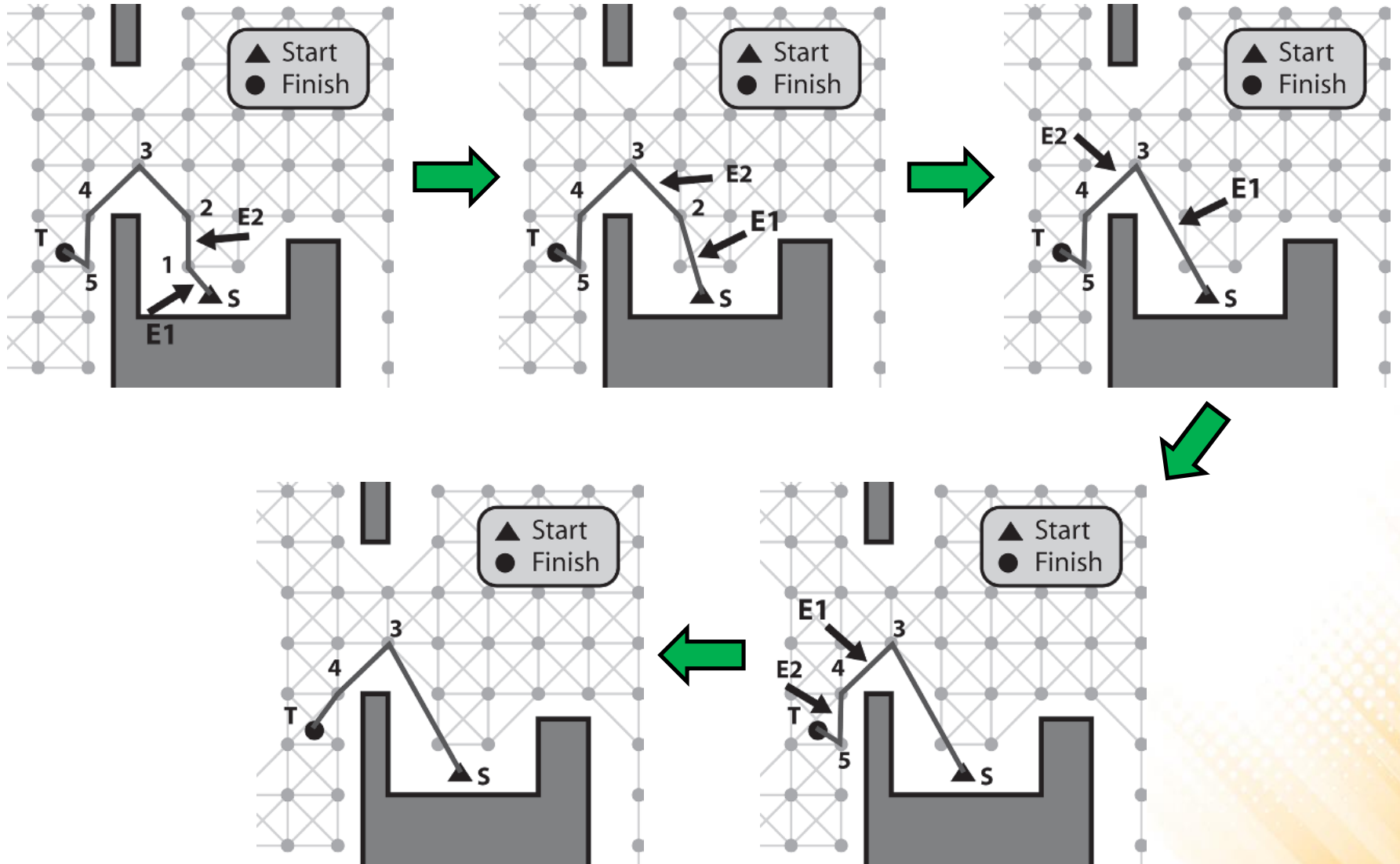

Navigation Mesh

- Tile-based graphs and points of visibility are useful solutions to simple problems, but the majority of modern games use navigation meshes.
- It takes advantage of the fact that the level designer already needs to specify the way the level is connected using polygons/triangles.
 - Can use level geometry or a new geometry created specially for navigation.

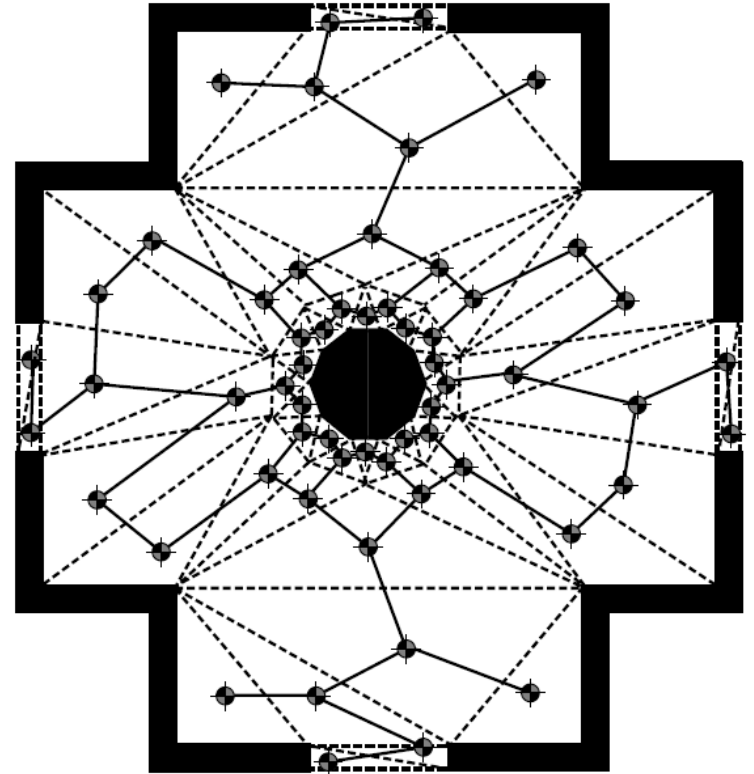

Navigation Mesh

- Instead of network of points, a navigation mesh comprises a network of convex polygons.
 - It has more information than waypoints (i.e., the agent can walk anywhere in the polygon);
 - While waypoints require a lot of points, the navigation mesh needs only few polygons to cover same area.

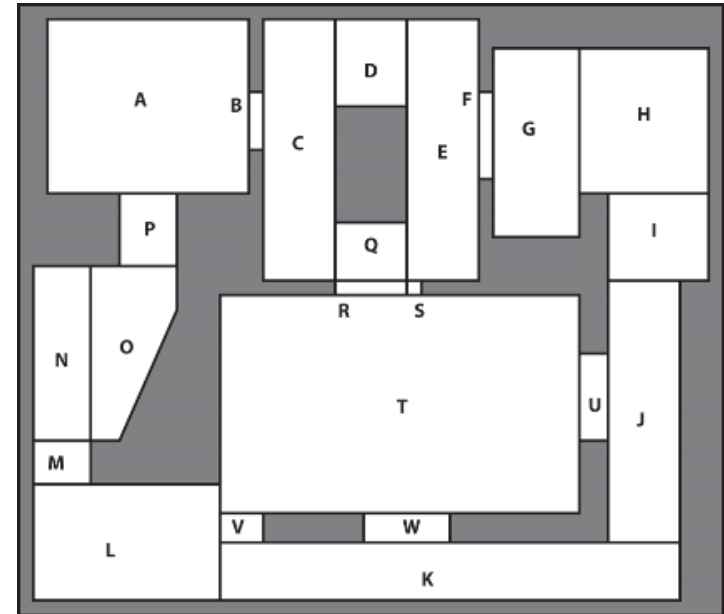
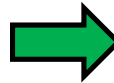
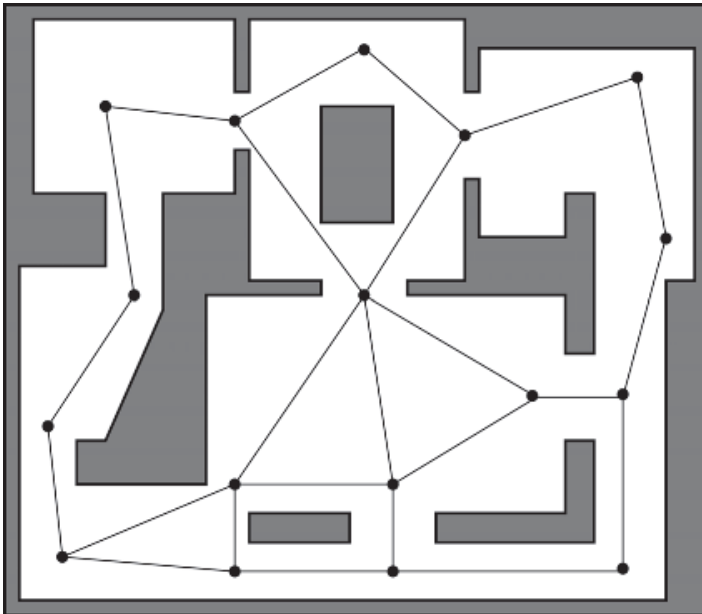

Navigation Mesh

- **Example 1:**



Waypoints
Graph

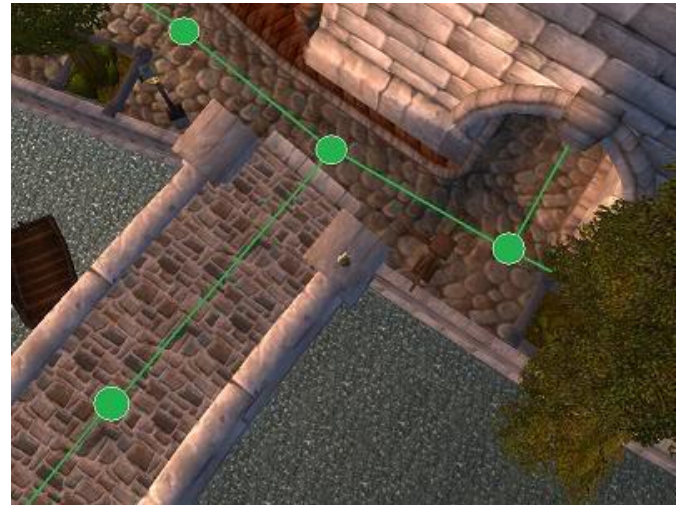

Navigation
Mesh



Navigation Mesh

- **Example 2:**



Waypoints
Graph



Navigation
Mesh



Optimization – Hierarchical Pathfinding

- Hierarchical pathfinding works in a similar way to how humans move around their environment.
 - Typically two hierarchical levels, but can be more.
 - First find a path in high-level, then refine in low-level.

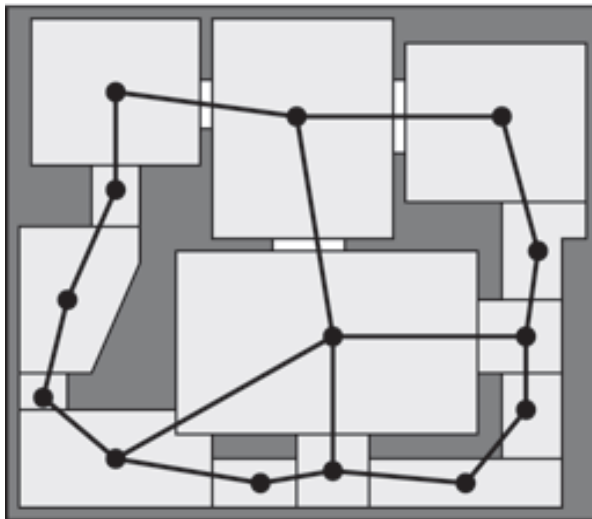

High-Level Graph

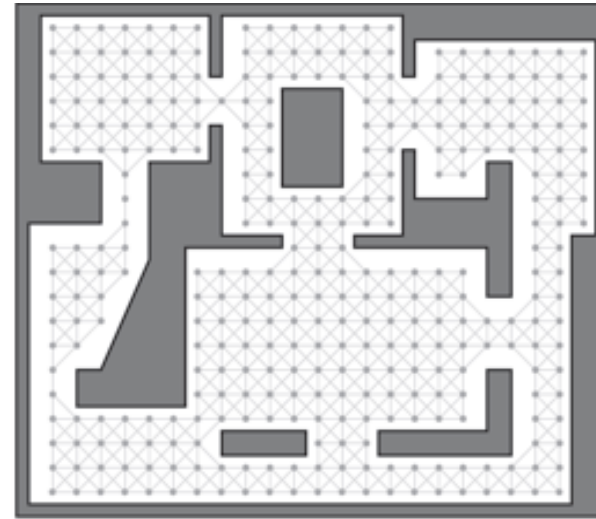

Low-Level Graph

Optimization – Pre-Calculated Paths

- If the game environment is static and memory usage is not a problem, a good option to reduce CPU load are pre-calculated path tables.

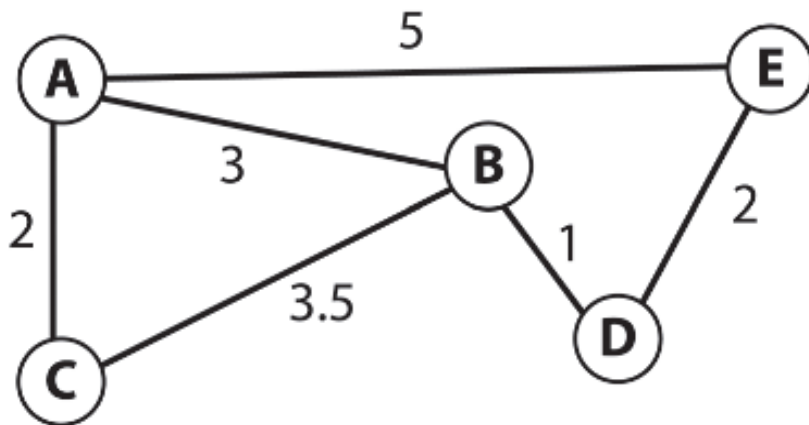

	A	B	C	D	E
A	A	B	C	B	E
B	A	B	C	D	D
C	A	B	C	B	B
D	B	B	B	D	E
E	A	D	D	D	E

Optimization – Pre-Calculated Costs

- Sometimes it's necessary for an agent to calculate the cost of traveling from one place to another. For example, to decide which is easiest item to get. This can be done with pre-calculated cost tables.

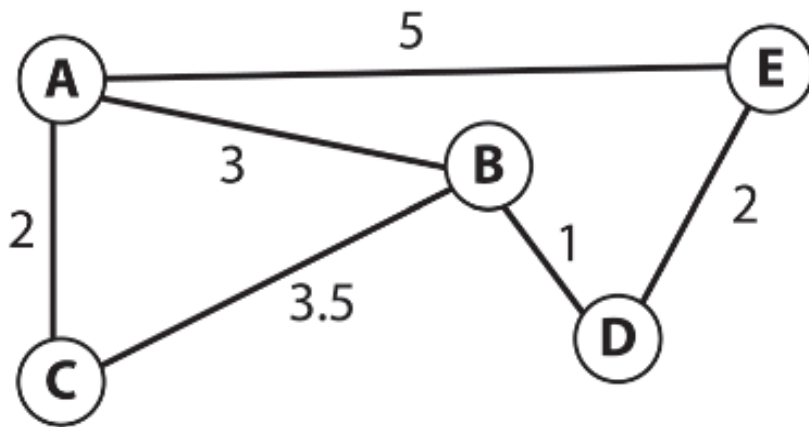

	A	B	C	D	E
A	0	3	2	4	5
B	3	0	3.5	1	3
C	2	3.5	0	4.5	6.5
D	4	1	4.5	0	2
E	5	3	6.5	2	0

Optimization – Other Techniques

- **Time-Sliced Pathfinding:** allocate a fixed amount of CPU resources per update step for all the search requests and distribute these resources evenly between the searches.
 - Considerable amount of coding work required!
- **Store Path Results:** save pathfinding results in memory and reuse them when necessary.
- **Recompute paths to avoid sticky situations:**

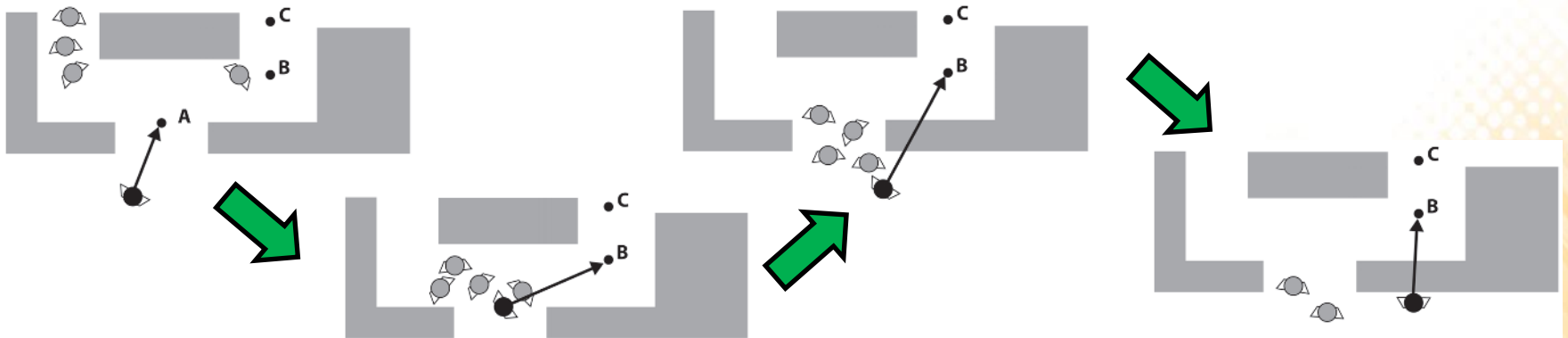

Unity Navigation System

- Unity's Navigation System allows characters to intelligently move around the game world. The system uses navigation meshes automatically created from the scene geometry.
- **NavMesh** – data structure that describes the walkable surfaces of the game world.
- **NavMesh Agent** – component to create moving characters.
- **Off-Mesh Link** – component that allows navigation shortcuts (e.g. jumps over holes, floors, or fences).
- **NavMesh Obstacle** – component to define moving obstacles that the agents should avoid while navigating the world.

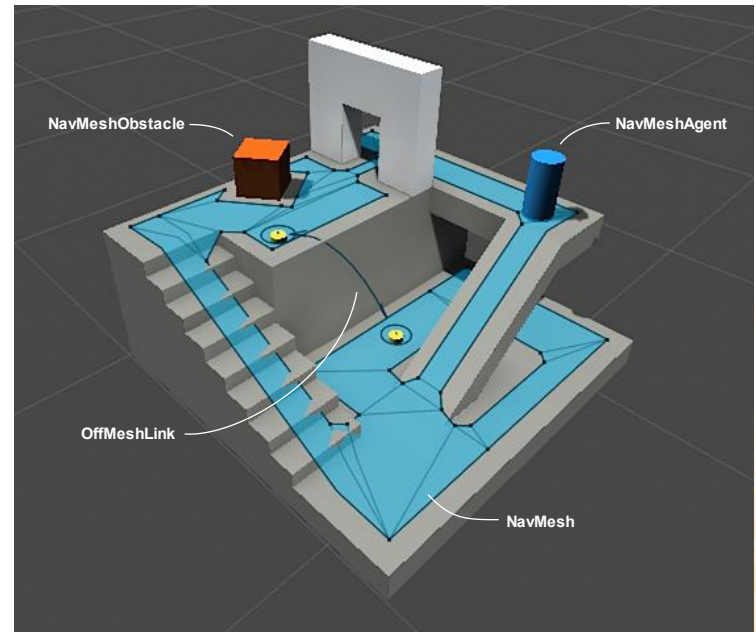

Unity Navigation System

- The process of creating a NavMesh from the level geometry uses the meshes of all Game Objects that are marked as Navigation Static, and processes them to create a navigation mesh that approximates the walkable surfaces of the level.

- **Navigation window:**
 - Window -> Navigation

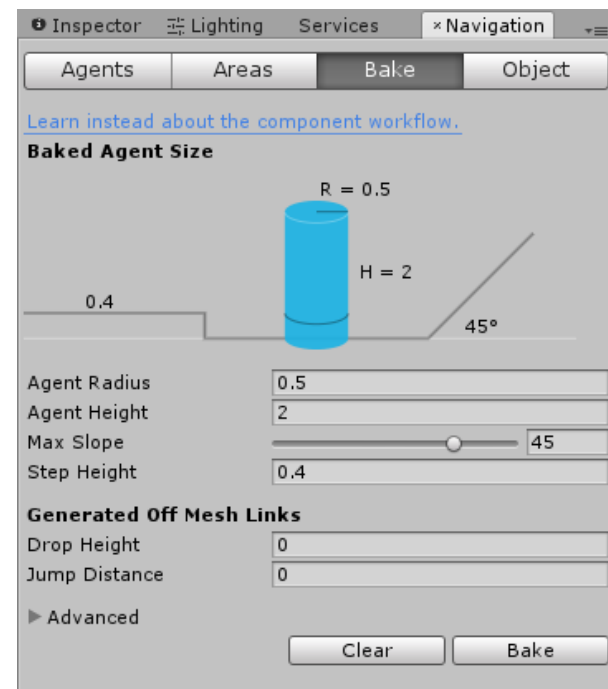

Unity Navigation System

- **Creating a basic NavMesh:**

- (Step 1): Select the objects that represent walkable surfaces and mark them as “Static Geometry” and “Walkable” in the Object tab of the Navigation Window.
- (Step 2): Select the objects that represent not walkable surfaces and mark them as “Static Geometry” and “Not Walkable” in the Object tab of the Navigation Window.

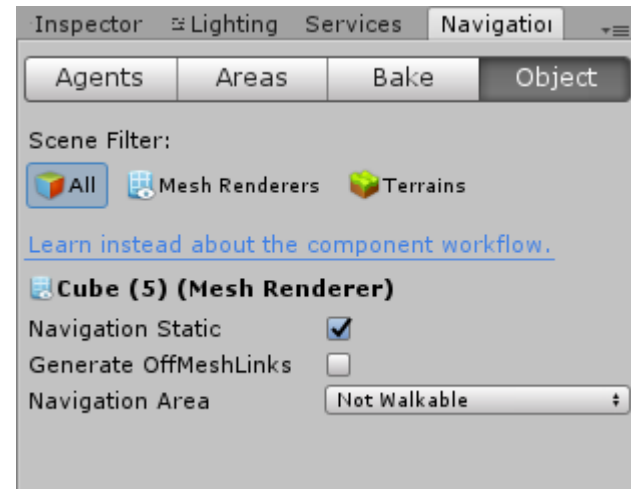
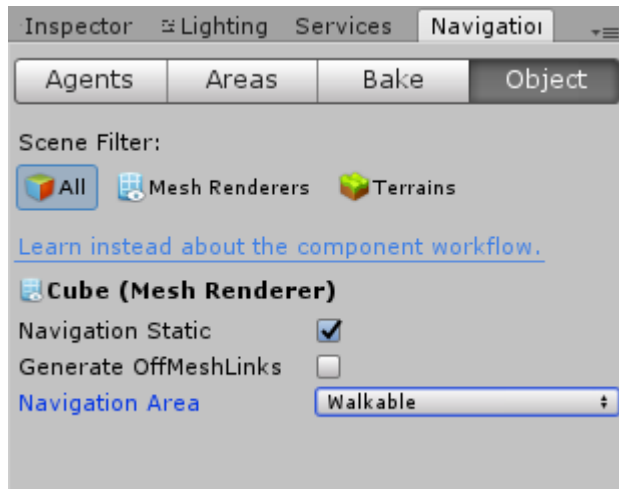

Unity Navigation System

- **Creating a basic NavMesh:**

- (Step 3): Adjust the bake settings to match the agent properties.

- **Agent Radius:** defines how close the agent center can get to a wall or a ledge.
 - **Agent Height:** defines how low the spaces are that the agent can reach.
 - **Max Slope:** defines how steep the ramps are that the agent walk up.
 - **Step Height:** defines how high obstructions are that the agent can step on.

- (Step 4): Click bake to build the NavMesh.

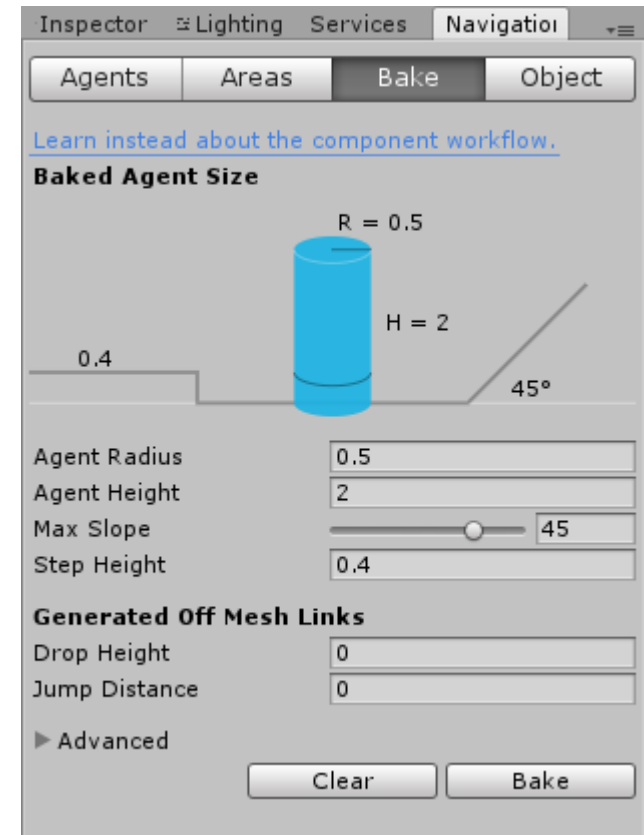

Unity Navigation System

- The resulting NavMesh will be shown in the scene as a blue overlay on the underlying level geometry:

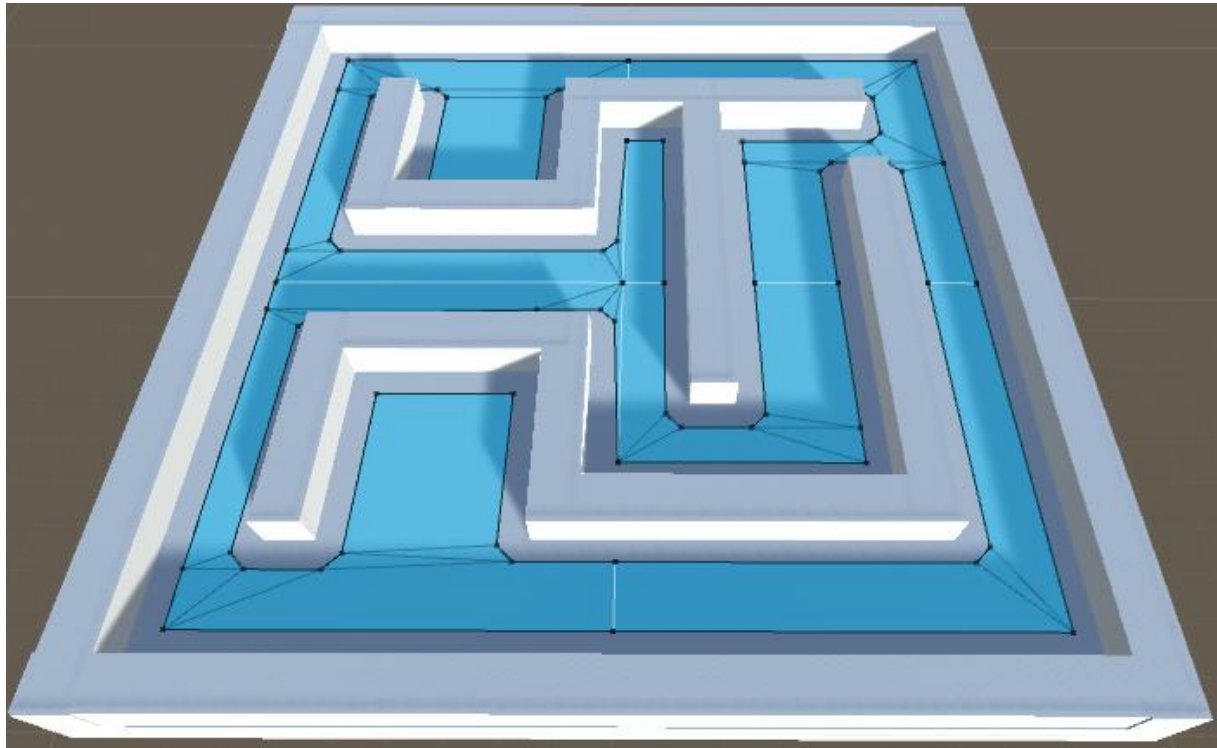

Unity Navigation System

- **Creating a NavMesh Agent:**

- (Step 1): Create an object to represent the agent (e.g. a cylinder).
- (Step 2): Add a NavMesh Agent component to the object (Component -> Navigation -> NavMesh Agent).
- (Step 3): If necessary, adjust the agent radius to match the object.

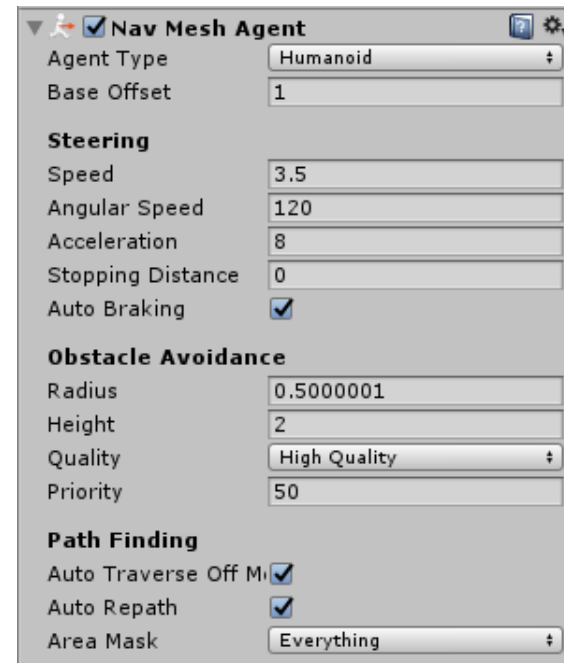
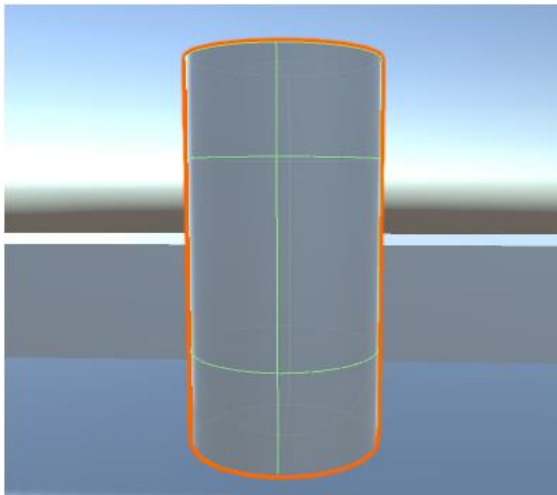

Unity Navigation System

- The NavMesh Agent component **handles both the pathfinding and the movement** of the character.
- The simplest way to move the agent towards a destination is done by setting the desired destination point by script.

```
public class AgentControl : MonoBehaviour {  
  
    public Transform goal;  
  
    void Start() {  
        NavMeshAgent agent = GetComponent<NavMeshAgent>();  
        agent.destination = goal.position;  
    }  
}
```

Unity Navigation System

- NavMesh Obstacle components can be used to describe obstacles the agents should avoid while navigating.
 - When an object obstructs the agent path, the Navigation System will automatically find another path (if there is one).

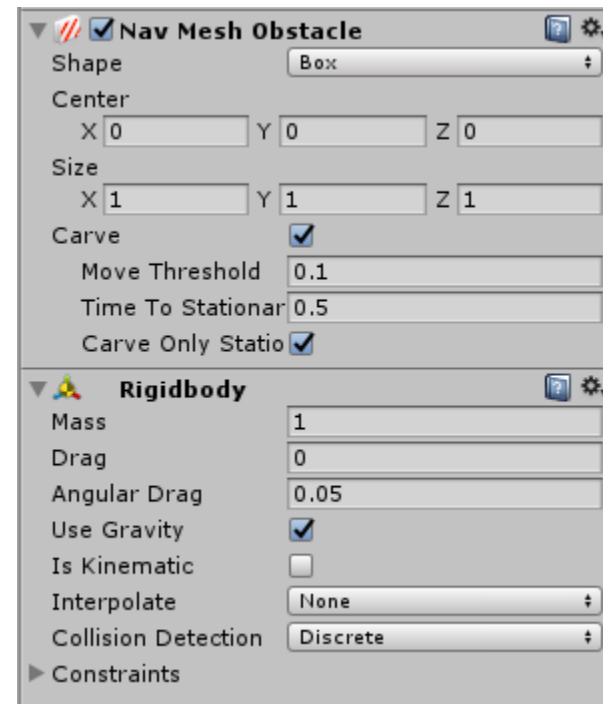
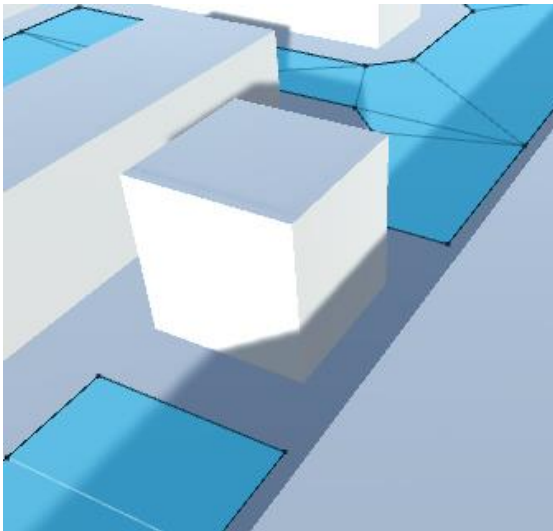

Unity Navigation System

- Off-Mesh Links are used to create paths crossing outside the walkable navigation mesh surface.
 - If the path via the off-mesh link is shorter than via walking along the NavMesh, the off-mesh link will be used.

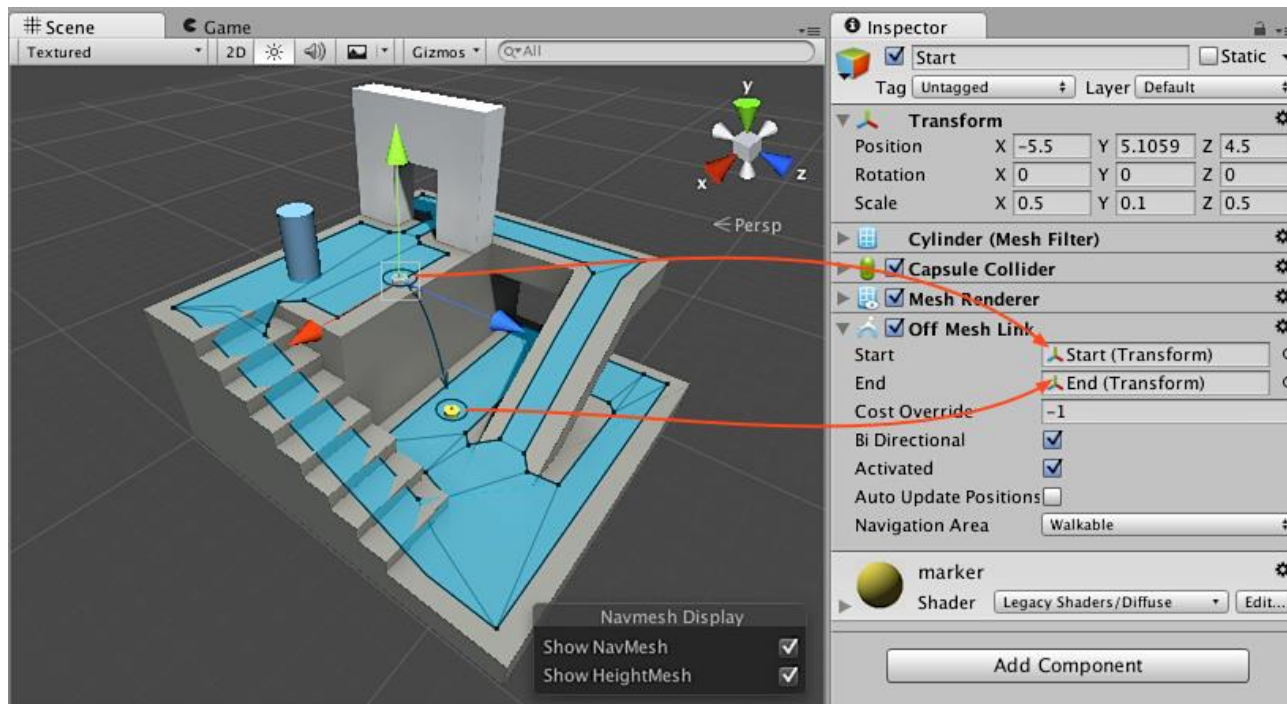

Unity Navigation System

- The Navigation Areas define how difficult it is to walk across a specific area, the lower cost areas will be preferred during path finding.
 - The cost per area type can be set globally in the Areas tab.

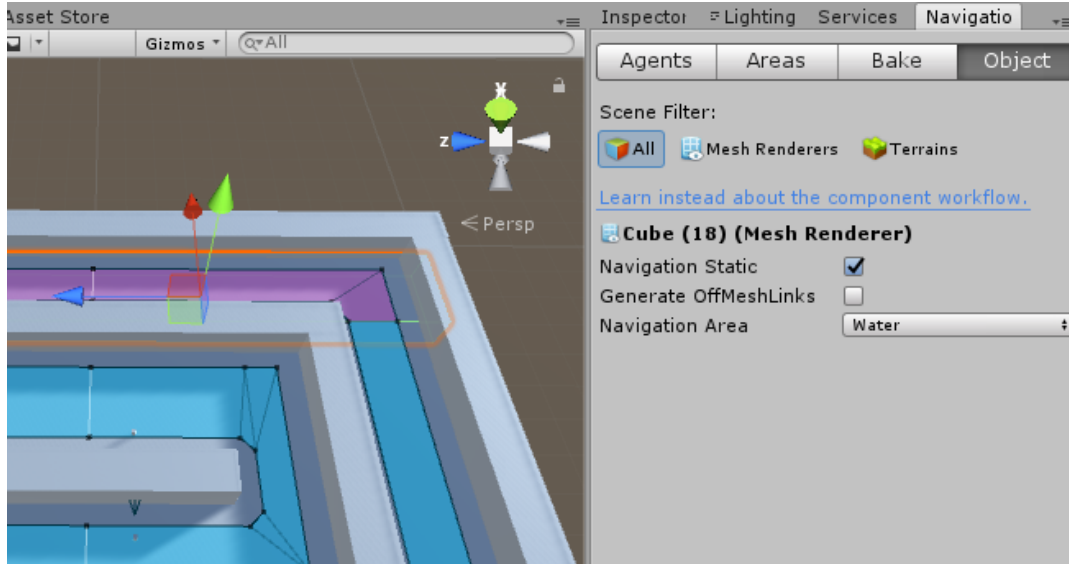

The screenshot shows the Unity Inspector window with the 'Navigation' tab selected. The 'Areas' sub-tab is active. It displays a table of global navigation area settings.

	Name	Cost
Built-in 0	Walkable	1
Built-in 1	Not Walkable	1
Built-in 2	Jump	2
User 3	Water	4
User 4		1
User 5		1
User 6		1
User 7		1
User 8		1
User 9		1
User 10		1
User 11		1
User 12		1
User 13		1

Exercise 5

- 5) Modify the scene created in Exercise 4 to use the Unity Navigation System.
 - a) Create the navigation mesh;
 - b) Create an agent;
 - c) Create a set of destination points;
 - d) Make the agent move through the destination points;
 - e) Add different costs to some of the corridors of the maze.

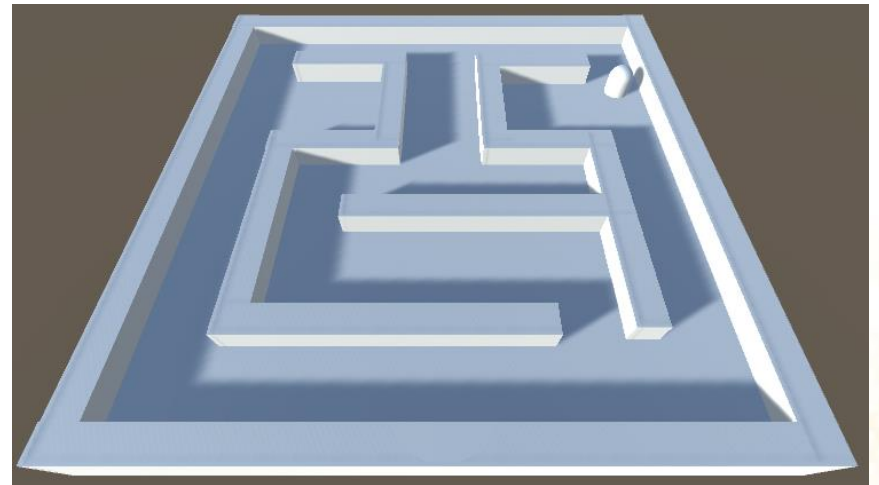

Further Reading

- Buckland, M. (2004). **Programming Game AI by Example**. Jones & Bartlett Learning. ISBN: 978-1-55622-078-4.

- **Chapter 8: Practical Path Planning**

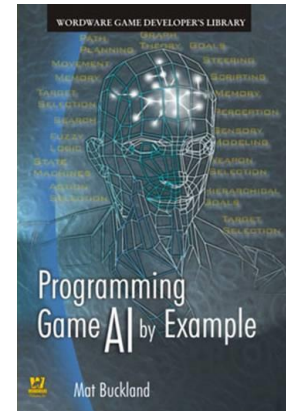

- Millington, I., Funge, J. (2009). **Artificial Intelligence for Games (2nd ed.)**. CRC Press. ISBN: 978-0123747310.

- **Chapter 4: Pathfinding**

